



# Product Catalogue

---

## Large Commercial Split System

Split System 23-55 Tons  
RAUP/TTV Models 50 Hz



---

September 2006

SSA5-PRC003-EN



# Contents

---

Model Number Description	4
General Data 20-55 Ton Condensing Units	6
General Data Blower Coil Units	7
System Performance Matrix	8
Features Summary	8
Outdoor Unit Application Considerations	9
Outdoor Unit Selection	10
Indoor Unit Fan Performance Data	11
Dimensional Data Condensing Unit RAUP 250	13
Dimensional Data Condensing Unit RAUP 300	14
Dimensional Data Condensing Unit RAUP 400	15
Dimensional Data Condensing Unit RAUP 500	16
Dimensional Data Condensing Unit RAUP 600	17
Dimensional Data DX Air Handling unit TTV 250	18
Dimensional Data DX Air Handling unit TTV 300	20
Dimensional Data DX Air Handling unit TTV 400	22
Dimensional Data DX Air Handling unit TTV 500	24
Dimensional Data DX Air Handling unit TTV 600	26
Mechanical Specifications Outdoor Unit	28
Mechanical Specifications Indoor Unit	29



# Model Number Description

---

## Unit Model Number Description

The product is identified by a multiple-character model number that precisely identifies a particular type of unit. An explanation is shown below. It will enable the owner or Service Engineer to define operation, components and applicable accessories for a specific unit.

<u>R</u>	<u>A</u>	<u>U</u>	<u>P</u>	<u>2</u>	<u>5</u>	<u>0</u>	<u>D</u>	<u>1</u>	<u>B</u>	<u>0</u>	<u>A</u>
1	2	3	4	5	6	7	8	9	10	11	12

**Digit No. 1** = Product Type  
R = Remote Condensing Unit

**Digit No. 2** = Product Type  
A = Air Cooled

**Digit No. 3** = Product Type  
U = Unit Airflow-Upflow

**Digit No. 4** = Development Sequence

**Digit No. 5, 6 and No. 7** = Nominal Gross Capacity (MBH)  
(Note: The Alphabetic Letter "O" is not used in Digit 6 or 7, Only the Number "0" is used.)  
250 = 250 MBH  
300 = 300 MBH  
400 = 400 MBH  
500 = 500 MBH  
600 = 600 MBH

**Digit No. 8** = Electrical Rating/Utilization Range  
D = 380-415V/3ph/50Hz

**Digit No. 9** = Motor/Compressor Controls  
(Note: The Alphabetic Letter "O" is not used in Digit 9, Only the Number "0" is used.)  
0 = None  
1 = DOL ( 3 wire ) Starter

**Digit No. 10** = Minor Design Sequence

**Digit No. 11** = Factory Installed/Shipped Options  
(Note: The Alphabetic Letter "O" is not used in Digit 11, Only the Number "0" is used.)  
0 = None  
1 = Blue fin  
2 = Suction/Liquid shut off valve  
3 = Crankcase Heater  
4 = Copper fin  
S = Special

**Digit No. 12** = Service Indicator



# Model Number Description

I I V 2 5 0 A D 0 1 A 0 A A 0 D  
 1 2 3 4 5 6 7 8 9 10 11 12 13 14 15 16

**Digit No 1, 2, 3 = Airflow Configuration**  
 V = Vertical Discharge

**Digit No 4, 5, 6 = Nominal Gross Capacity (MBH)**

**Digit No 7 = Major Design Sequence**

**Digit No 8 = Electrical Rating / Utilization Range**  
 D = 380-415V/3Ph/50Hz

**Digit No 9 = Motor Control**  
 0 = None  
 1 = DOL 4 wire

**Digit No 10 = Factory Installed Options**

0 = No Motor and Drive  
 1 = 3.7 Supply Fan Motor kW  
 2 = 5.5 Supply Fan Motor kW  
 3 = 7.5 Supply Fan Motor kW  
 4 = 11 Supply Fan Motor kW  
 5 = 15 Supply Fan Motor kW

MODEL	MOTOR SIZE		
	STANDARD	OVER SIZE - 1	OVER SIZE - 2
TTV250	5 hp (3.7 kW)	7.5 hp (5.5 kW)	10 hp (7.5 kW)
TTV300	7.5 hp (5.5 kW)	10 hp (7.5 kW)	15 hp (11 kW)
TTV400	7.5 hp (5.5 kW)	10 hp (7.5 kW)	15 hp (11 kW)
TTV500	10 hp (7.5 kW)	15 hp (11 kW)	20 hp (15 kW)
TTV600	15 hp (11 kW)	20 hp (15 kW)	-----

**Digit No 11 = Minor Design Sequence**

**Digit No 12**  
 0 = No Discharge Plenum  
 1 = With Discharge Plenum (For TTV250&300)

**Digit No 13**  
 A = Internal Filter Rack ; 1" Filter  
 B = External Filter Rack ; 2" Filter  
 C = Internal Filter Rack ; 1" Filter with Decorative Return Air Grille

**Digit No 14 = Arrangement**  
 A = Arrangement 1  
 B = Arrangement 2  
 C = Arrangement 3  
 D = Arrangement 4

**Digit No 15 = Future Use**

**Digit No 16 = Service**



# General Data 20-55 Ton Condensing Units

Table 1

UNIT MODELS		RAUP 250	RAUP 300	RAUP 400	RAUP 500	RAUP 600
<b>POWER CONNECTION</b>	V/ph/Hz			380-415/3/50		
<b>MCA<sup>1</sup></b>	A	53.6	57.5	91.1	101.4	109
Unit Capacity Steps (%)		100-50	100-50	100-75-50-25	100-75-50-25	100-75-50-25
<b>SYSTEM DATA</b>						
Refrigerant Type		R22	R22	R22	R22	R22
No. Refrigerant Circuits		1	1	2	2	2
Refrigerant Connection Type		Sweat	Sweat	Sweat	Sweat	Sweat
Refrigerant Charge approximate per circuit	lb (kg)	44 (20)	60.6 (27.5)	43 (19.5)	44 (20)	60.6 (27.5)
Suction Line OD	in (mm)	2-1/8	2-1/8	1-5/8	2-1/8	2-1/8
Liquid line OD	in (mm)	7/8	7/8	7/8	7/8	7/8
<b>COMPRESSOR</b>						
Compressor Type		Scroll	Scroll	Scroll	Scroll	Scroll
No. Used		2	2	4	4	4
Model		13T-13T	15T+15T	2x(10T+10T)	2x(13T+13T)	2x(15T+15T)
Speed Number		1	1	1	1	1
V/ph/Hz				380-415/3/50		
RLA/LRA (each) <sup>2</sup>	A	22.9/135	24.2/175	20.7/130	22.9/135	24.2/175
Motor RPM	rpm	2900	2900	2900	2900	2900
<b>COIL</b>						
No. Used		1	1	2	2	2
Face Area	sq ft (m <sup>2</sup> )	31.06 (2.88)	35.00 (3.25)	45.36 (4.21)	57.19 (5.31)	66.66 (6.21)
Tube Size OD	in (mm)	3/8 (9.5)	3/8 (9.5)	3/8 (9.5)	3/8 (9.5)	3/8 (9.5)
Rows		3	3	3	3	3
Fins per inch		12	12	12	12	12
<b>FAN</b>						
Fan Type		Propeller	Propeller	Propeller	Propeller	Propeller
No. used		2	3	3	4	6
Diameter	in (mm)	(28) 710	(28) 710	(28) 710	(28) 710	(28) 710
No. of Blade		4	4	4	4	4
Drive Type		Direct	Direct	Direct	Direct	Direct
Nominal Airflow <sup>3</sup>	cfm (cmh)	11,500 (19,539)	15,000 (25,485)	17,100 (29,053)	22,280 (37,853)	29,400 (49,950)
<b>MOTOR</b>						
No. of Motor		2	3	3	4	6
Motor hp (each)	hp (kW)	0.4 (0.3)	0.4 (0.3)	0.4 (0.3)	0.4 (0.3)	0.4 (0.3)
No. of Speed		1	1	1	1	1
Motor Speed	rpm	875	875	875	875	875
V/ph/Hz				380-415/3/50		
RLA/LRA (each)		1.03/2.80	1.03/2.80	1.03/2.80	1.03/2.80	1.03/2.80
<b>DIMENSION (HxWxD)</b>						
Crated (Shipping)	in	65x98x54	65x124x54	63x110x82	75x110x82	67x124x82
	mm	1,642x2,489x1,372	1,642x3,150x1,372	1,591x2,794x2,083	1,895x2,794x2,083	1,692x3,150x2,083
Uncrated (Net)	in	58x88x48	58x115x48	56x99x76	68x99x76	60x115x76
	mm	1,465x2,229x1,206	1,465x2,910x1,206	1,414x2,513x1,920	1,718x2,513x1,920	1,515x2,910x1,920
<b>WEIGHT</b>						
Crated (Shipping)	lb (kg)	1,336 (606)	1,676 (760)	2,284 (1,036)	2,659 (1,206)	2,745 (1,245)
Uncrated (Net)	lb (kg)	1,292 (586)	1,631 (740)	2,207 (1,001)	2,582 (1,171)	2,668 (1,210)

<sup>1</sup> MCA - Minimum Circuit Ampacity is 125% of the largest compressor RLA plus 100% of the other compressor RLA plus the sum of the motor RLA.

<sup>2</sup> At 7 deg C SST and 35 deg C Ambient, Subcooling 8.3 K, Superheat 11.1 K.

<sup>3</sup> Nominal Airflow is rated with standard air-dry coil.



# General Data Blower Coil Units

Table 2

UNIT MODELS		TTV 250	TTV 300	TTV 400	TTV 500	TTV 600
<b>POWER CONNECTION</b>	V/ph/Hz			380-415/3/50		
MCA <sup>1</sup>	A	9.4	14.6	14.6	18.2	26.6
<b>SYSTEM DATA</b>						
Refrigerant Type		R22	R22	R22	R22	R22
No. Refrigerant Circuits		2	2	2	2	2
Refrigerant Connection Type		Brazed	Brazed	Brazed	Brazed	Brazed
Suction Line OD	in (mm)	2-1/8 (53.98)	1-5/8 (41.28)	2-1/8 (53.98)	2-1/8 (53.98)	2-1/8 (53.98)
Liquid Line OD	in (mm)	5/8 (15.88)	7/8 (22.23)	1-1/8 (28.58)	1-1/8 (28.58)	1-1/8 (28.58)
<b>COIL</b>						
Face Area	sq ft (m <sup>2</sup> )	16.7 (1.55)	19.2 (1.78)	25.6 (2.38)	34.8 (3.24)	38.0 (3.53)
Tube Size OD	in (mm)	3/8 (9.53)	3/8 (9.53)	3/8 (9.53)	1/2 (12.7)	1/2 (12.7)
Rows		3	3	3	4	4
Fins per inch		12	12	12	12	12
Refrigerant Flow Control		Expansion Valve	Expansion Valve	Expansion Valve	Expansion Valve	Expansion Valve
Drain Connection Size	in (mm)	1-1/4 (31.8)	1-1/4 (31.8)	1-1/4 (31.8)	1-1/4 (31.8)	1-1/4 (31.8)
<b>FAN</b>						
Fan Type		Centrifugal FC	Centrifugal FC	Centrifugal FC	Centrifugal FC	Centrifugal FC
No. used		1	1	2	2	2
Diameter	in (mm)	15.7 (400)	15.7 (400)	15.4 (390)	17.7 (450)	17.7 (450)
Width	in (mm)	12.6 (320)	12.6 (320)	15.4 (390)	14.2 (360)	14.2 (360)
Fixed Drive Type		Belt and Pulley	Belt and Pulley	Belt and Pulley	Belt and Pulley	Belt and Pulley
Fan Pulley Pitch Diameter	in	9	10	11	13	13
Fan Speed - Std. (Factory set)	rpm	828	870	923	725	780
Airflow <sup>2</sup>	cfm (cmh)					
- Nominal		7,760 (13,180)	9,240 (15,700)	12,120 (20,590)	15,130 (25,700)	18,080 (30,720)
<b>MOTOR</b>						
Motor Type				TEFC		
No. of Motor		1	1	1	1	1
Motor hp - Std.	hp (kW)	5 (3.7)	7.5 (5.5)	7.5 (5.5)	10 (7.5)	15 (11)
Hi Static		7.5 (5.5) / 10 (7.5)	10 (7.5) / 15 (11)	10 (7.5) / 15 (11)	15 (11) / 20 (15)	20 (15)
No. of Speed		1	1	1	1	1
Motor Pulley Pitch Diameter	in	5	6	7	6.5	7
V/ph/Hz				380-415/3/50		
RLA/LRA		7.5/53.5	11.64/93	11.64/93	14.53/116	21.25/168
<b>FILTER</b>						
Type		Washable	Washable	Washable	Washable	Washable
No. used		8	9	9	12	9
Size (WxLxD) - Std.	in	16x20x1	4-5x20x1 2-16x20x1 1-16x25x1 2-15x25x1	6-16x25x1 3-20x25x1	2-16x20x1 6-16x25x1 1-20x25x1 3-25x25x1	3-20x20x1 6-20x25x1
<b>DIMENSION (HxWxD)</b>						
Uncrated (Net)	mm	1,219x1,808x1,040	1,372x1,808x1,040	1,520x2,088x1,040	1,653x2,596x1,275	1,777x2,596x1,275
<b>WEIGHT</b>						
Uncrated (Net)	kg (lbs)	353 (778)	421 (928)	487 (1,073)	685 (1,510)	749 (1,651)

<sup>1</sup> MCA - Minimum Circuit Ampacity ; calculated as follow : 125% of heater R.L Amps plus the fan motor R.L Amps.

<sup>2</sup> CFM is rated with standard air-dry coil.



# System Performance Matrix

Table 3

MODEL		Evaporator Airflow		Total Capacity		Sensible Capacity	
Outdoor	Indoor	CFM	CMH	MBH	kW	MBH	kW
RAUP 250	TTV 250	7760	13184	278	81	197	58
RAUP 300	TTV 250	7760	13184	318	93	213	62
RAUP 300	TTV 300	9240	15699	333	98	237	69
RAUP 400	TTV 300	9240	15699	388	114	260	76
RAUP 400	TTV 400	12120	20592	421	123	303	89
RAUP 500	TTV 400	12120	20592	504	148	338	99
RAUP 500	TTV 500	15130	25706	541	159	395	116
RAUP 600	TTV 500	15130	25706	622	182	429	126
RAUP 600	TTV 600	18080	30718	658	193	493	144

Capacities based on ambient temperature of 95°F (35°C) Coil on coil temperature of 80/67°F (26/19°C) EDB/EWB. Capacities are gross and do not include the evaporator fan motor heat deduction

## Features Summary

Features	Benefits
<ul style="list-style-type: none"> <li>• Scroll Compressors</li> </ul>	<ul style="list-style-type: none"> <li>• High compressor EERs.</li> <li>• Less vibration and a Quieter Operation</li> <li>• Durability / Extended Life Built in dirt separator to prevent dirt reaching the bearings High volume oil sump prevents excessive oil loss.</li> <li>• Compressor Protection Internal motor temperature sensor. Current overloads External high and low pressure switches</li> <li>• Tandem Capability Achieves high part load efficiencies and additional part load control.</li> <li>• Sight glass &amp; oil charging valves</li> <li>• DOL Starter, minimizing field installation.</li> </ul>
<ul style="list-style-type: none"> <li>• Micro Controller with labled and numbered wiring.</li> </ul>	<ul style="list-style-type: none"> <li>• Helps in troubleshooting and reduces service time.</li> <li>• Detailed two digits troubleshooting diagnostics.</li> <li>• Higher Controller reliability than traditional hard wired systems</li> </ul>
<ul style="list-style-type: none"> <li>• Robust Casing</li> </ul>	<ul style="list-style-type: none"> <li>• Stainless Steel &amp; Corrosion Resistant Coated external screws.</li> <li>• Corrosion resistant coated coils as an option.</li> <li>• High efficiency Trane slit fin coils.</li> <li>• Weather resisant baked matt polyester powder painted GI panels. Heavy gauge welded steel base with mounting holes.</li> <li>• IP 55 condenser fan motors with built in thermal overloads.</li> <li>• Aluminium Blade propeller fans.</li> <li>• Fully factory leak and pressure, tested.</li> </ul>
<ul style="list-style-type: none"> <li>• Factory Packaged</li> </ul>	<ul style="list-style-type: none"> <li>• DOL Starters, Filter driers, controller</li> </ul>
<ul style="list-style-type: none"> <li>• Pre Matched Compact Air Handlers</li> </ul>	<ul style="list-style-type: none"> <li>• Small foot print</li> <li>• Multiple fan arrangements. Vertical or horizontal discharge configurations.</li> <li>• Up to 2.5" (625Pa) ESP</li> <li>• Baked Polyester Powder Painted GI panels</li> <li>• 25 mm Aluminium foil faced fiberglass insulation.</li> <li>• Double Inlet Width Forward curved fans</li> <li>• Standard 25 mm washable air filters.</li> <li>• Oversized motor options for higher static operation.</li> </ul>

\* Some items are optional and not standard.



# Outdoor Unit Application Considerations

---

Certain application constraints should be considered when sizing, selecting and installing Trane air-cooled condensing units. Unit reliability is dependent upon these considerations. Where your application varies from the guidelines presented, it should be reviewed with the local Trane sales engineer.

## Unit Sizing

Intentionally oversizing a unit to assure adequate capacity is not recommended. Erratic system operation and excessive compressor cycling are often a direct result of an oversized condensing unit. In addition, an oversized units usually more expensive to purchase, install and operate. If oversizing is desired, consider using two units.

## Unit Placement

A base or foundation is not required if the selected unit location is level and strong enough to support the unit's operating weight.

## Isolation and Sound Emission

The most effective form of isolation is to locate the unit away from any sound sensitive area. Structurally transmitted sound can be reduced by using spring or rubber isolators. The isolators are effective in reducing the low frequency sound generated by compressors and, therefore are recommended for sound sensitive installations. An acoustical engineer should always be consulted on critical applications. For maximum isolation effect, the refrigeration lines and electrical conduct should also be isolated. Use flexible electrical conduit. State and local codes on sound emissions should always be considered. Since the environment in which a sound source is located affects sound pressure, unit placement must be carefully evaluated.

## Unit Location

Unobstructed flow of condenser air is essential for maintaining condensing unit capacity and operation efficiency. When determining unit placement, careful consideration must be given to assure proper air flow across the condenser heat transfer surface. Failure to heed these considerations will result in warm air recirculation and coil air flow starvation, resulting in a high pressure compressor cutoff.

Warm air recirculation occurs when discharge air from the condenser fans is recycled back at the condenser coil inlet. Coil starvation occurs when free air flow to the condenser is restricted.

Both warm air recirculation and coil starvation cause reductions in unit efficiency and capacity. In addition, in more severe cases, nuisance unit shutdowns will result from excessive head pressures. Accurate estimates of the degree of efficiency and capacity reduction are not possible due to the unpredictable effect of varying winds, temperatures and coil conditions.

In addition, wind tends to further reduce head pressure. Therefore, it is advisable to protect the air-cooled condensing unit from continuous direct winds exceeding 10 miles per hour.

Debris, trash, supplies, etc., should not be allowed to accumulate in the vicinity of the air-cooled condensing unit. Supply air movement may draw debris between coil fins and cause coil starvation. Special consideration should be given to units operating in low ambient temperatures. Condenser coils and fan discharge must be kept free of snow and other obstructions to permit adequate air flow for satisfactory unit operation.

## Effect of Altitude On Capacity

Condensing unit capacities given in the performance data tables. At elevations substantially above sea level, the decreased air density will decrease condenser air density will decrease condenser capacity and efficiency.

## Ambient Considerations

Start up and operation at lower ambients requires sufficient head pressure be maintained for proper expansion valve operation.

At higher ambients, excessive head pressure may result. Standard operating ambients are 7-45°C. With a low ambient kit comprising crank case heaters and frequency inverters, operation below 7°C is achievable. Minimum ambient condition are based on still conditions.

## Refrigerant Piping

Special consideration must always be given to oil return. Minimum suction gas velocities must always be maintained for proper oil return.



# Outdoor Unit Selection

## SYSTEM PERFORMANCE DATA

Table 6

Outdoor Unit	Indoor Unit	Indoor Unit CFM	Evap. On Coil Temp. F		75			86			95			104		
			EDB F	EWB F	TC	SHC	PI	TC	SHC	PI	TC	SHC	PI	TC	SHC	PI
RAUP 250	TTV 250	7760	75	61	276.1	218.1	16.5	264.3	211.5	18.6	251.8	206.4	21.0	238.6	200.4	23.7
			77	64	290.1	208.9	16.5	277.8	205.5	18.6	259.8	194.9	21.0	250.9	193.2	23.7
			80	67	304.3	207.0	16.5	292.0	204.4	18.6	277.9	197.3	21.0	262.1	191.3	23.7
			86	71	-	-	-	-	-	-	-	-	-	-	-	-
RAUP 300	TTV 250	7760	75	61	-	-	-	296.8	228.6	22.4	284.9	222.2	25.2	271.5	217.2	28.2
			77	64	325.9	224.9	19.8	312.5	218.7	22.4	287.8	207.2	25.2	283.4	206.9	28.2
			80	67	345.6	224.7	19.8	331.9	219.1	22.4	317.6	212.8	25.2	301.8	208.3	28.2
			86	71	367.5	238.9	19.8	354.0	233.6	22.4	339.0	227.1	25.2	322.2	219.1	28.2
	TTV 300	9240	75	61	205.7	164.5	14.3	197.1	251.4	22.4	300.8	246.7	25.2	285.6	239.9	28.2
			77	64	216.6	157.8	14.5	207.5	241.2	22.4	315.8	236.9	25.2	299.0	230.3	28.2
			80	67	227.8	156.6	14.8	218.2	239.9	22.4	333.1	236.5	25.2	316.5	227.9	28.2
			86	71	243.2	165.8	15.1	232.8	-	-	-	-	-	-	-	-
RAUP 400	TTV 300	9240	75	61	-	-	-	-	-	-	-	-	-	-	-	-
			77	64	404.3	274.9	26.4	387.5	267.4	29.8	368.5	261.6	33.6	350.6	252.4	37.8
			80	67	422.6	274.6	26.4	407.0	268.6	29.8	388.3	260.2	33.6	370.5	251.9	37.8
			86	71	452.0	289.3	26.4	434.0	282.1	29.8	414.2	273.4	33.6	393.7	267.7	37.8
	TTV 400	12120	75	61	419.3	335.4	26.4	398.7	326.9	29.8	379.7	315.2	33.6	359.2	308.9	37.8
			77	64	443.5	323.8	26.4	423.4	313.3	29.8	401.0	304.7	33.6	378.6	295.3	37.8
			80	67	462.1	318.9	26.4	442.0	313.8	29.8	421.1	303.2	33.6	397.8	294.3	37.8
			86	71	-	-	-	-	-	-	-	-	-	-	-	-
RAUP 500	TTV 400	12120	75	61	-	-	-	-	-	-	-	-	-	-	-	-
			77	64	524.2	361.7	33.0	502.9	352.0	37.2	480.5	341.1	42.0	455.8	328.2	47.4
			80	67	545.3	354.5	33.0	525.8	347.1	37.2	504.0	337.7	42.0	479.8	326.3	47.4
			86	71	585.2	374.5	33.0	562.7	365.8	37.2	539.4	356.0	42.0	511.7	348.0	47.4
	TTV 500	15130	75	61	536.3	439.7	33.0	513.2	425.9	37.2	489.8	416.3	42.0	463.7	370.9	47.4
			77	64	564.5	417.7	33.0	539.8	410.3	37.2	515.2	396.7	42.0	487.2	384.9	47.4
			80	67	592.0	420.3	33.0	568.3	409.1	37.2	541.4	395.2	42.0	514.1	385.6	47.4
			86	71	-	-	-	-	-	-	-	-	-	-	-	-
RAUP 600	TTV 500	15130	75	61	-	-	-	-	-	-	-	-	-	-	-	-
			77	64	640.6	454.9	39.6	616.0	443.5	44.8	591.4	413.7	50.4	553.3	415.0	56.4
			80	67	667.6	447.3	39.6	644.0	437.9	44.8	621.7	429.0	50.4	592.0	420.3	56.4
			86	71	717.1	480.5	39.6	692.0	470.6	44.8	663.9	458.1	50.4	632.4	442.6	56.4
	TTV 600	18080	75	61	645.1	541.9	39.6	621.2	528.0	44.8	594.0	516.8	50.4	564.0	502.0	56.4
			77	64	682.1	518.4	39.6	656.3	511.9	44.8	627.2	495.5	50.4	594.7	481.7	56.4
			80	67	713.6	513.7	39.6	685.8	507.5	44.8	657.6	493.1	50.4	622.9	479.7	56.4
			86	71	-	-	-	-	-	-	-	-	-	-	-	-

**Note :** EDB = Entering Dry Bulb, deg. F  
 EWB = Entering Wet Bulb, deg. F  
 TC = Total Capacity, MBH  
 SHC = Sensible Heat Capacity, MBH  
 PI = Power Input, kW Compressors  
 All capacities are gross and do not include a deduction for evaporator fan motor heat.  
 Interpolation is allowed. Do not extrapolate.

## Correction Factors

Cooling Capacity Correction Factor for CFM/CMH, other than standard

%CFM.CMH Variation From Rated	-20	-10	Rated	+10	+20
Total Cooling Capacity Multiplier	0.96	0.98	1.00	1.02	1.03
Sensible Heat Multiplier	0.91	0.96	1.00	1.04	1.08

Note : Calculate total and sensible capacities in MBH and multiply by above factors to determine revised capacities



# Indoor Unit Fan Performance Data

## Evaporator Fan Performance - TTV 250

English Units

		External Static Pressure (in. wg)																		
		0.5		0.6		0.8		1.0		1.2		1.4		1.6		1.8		2.0		
CFM	RPM	BHP	RPM	BHP	RPM	BHP	RPM	BHP	RPM	BHP	RPM	BHP	RPM	BHP	RPM	BHP	RPM	BHP	RPM	BHP
6207	634	1.9	661	2.0	713	2.3	764	2.5	812	2.8	860	3.1	907	3.4	953	3.7	999	4.1	1002	4.4
6760	662	2.2	687	2.3	736	2.7	784	2.8	831	3.1	876	3.5	919	3.8	961	4.1	1002	4.4		
7760	725	3.1	748	3.3	791	3.5	834	4.0	876	4.2	917	4.4	958	4.8	999	5.2	1036	5.5		
7880	732	3.2	755	3.4	798	3.6	840	4.1	881	4.3	922	4.6	963	4.9	1003	5.3	1040	5.7		
9010	805	4.5	825	4.7	866	5.1	903	5.3	941	5.9	977	6.3	1013	6.5	1049	6.8	1065	7.1		
9460	835	5.1	855	5.3	894	5.8	931	6.1	967	6.5	1001	7.0	1036	7.3	1071	7.7	1105	8.0		

- Notes:**
- Standard motor is 5 hp (3.7 kW), 1<sup>st</sup> option high static motor is 7.5 hp (5.5 kW), 2<sup>nd</sup> option high static motor is 10 hp (7.5 kW)
  - To determine the power of the motor to be installed, the following correction factors have to be applied to the fan Shaft Absorbed hp.  
 Fan motor hp = Absorbed Fan Shaft hp x Correction Factor  
 Correction Factor = 1.2 for Absorbed Fan Shaft < 10 kW (13.4 hp)  
 Correction Factor = 1.15 for Absorbed Fan Shaft > 10 kW (13.4 hp)  
 Fan Motor Heat (MBH) = 2.55 x BHP  
 Data Includes wet coil pressure drop

## Evaporator Fan Performance - TTV 300

English Units

		External Static Pressure (in. wg)																		
		0.5		0.6		0.8		1.0		1.2		1.4		1.6		1.8		2.0		
CFM	RPM	BHP	RPM	BHP	RPM	BHP	RPM	BHP	RPM	BHP	RPM	BHP	RPM	BHP	RPM	BHP	RPM	BHP	RPM	BHP
7440	692	2.7	717	2.9	762	3.2	807	3.5	851	3.8	894	4.0	936	4.4	976	4.7	1016	5.1		
7880	719	3.1	743	3.3	786	3.5	829	4.0	870	4.3	911	4.5	952	4.8	992	5.2	1030	5.6		
9000	790	4.4	810	4.5	852	5.0	890	5.2	927	5.6	964	6.2	1000	6.4	1036	6.6	1072	7.0		
9240	806	4.7	825	4.9	866	5.3	904	5.6	940	6.0	977	6.5	1012	6.8	1047	7.1	1082	7.4		
10130	865	6.0	882	6.1	919	6.5	956	7.0	990	7.3	1023	7.7	1057	8.3	1089	8.8	1121	9.1		
11260	924	8.0	958	8.2	990	8.5	1023	9.0	1057	9.6	1088	9.9	1118	10.2	-	-	-	-		

- Notes:**
- Standard motor is 7.5 hp (5.5 kW), 1<sup>st</sup> option high static motor is 10 hp (7.5 kW), 2<sup>nd</sup> option high static motor is 15 hp (11 kW)
  - To determine the power of the motor to be installed, apply the following correction factors to the fan Shaft Absorbed hp.  
 Fan motor hp = Absorbed Fan Shaft hp x Correction Factor  
 Correction Factor = 1.2 for Absorbed Fan Shaft < 10 kW (13.4 hp)  
 Correction Factor = 1.15 for Absorbed Fan Shaft > 10 kW (13.4 hp)  
 Fan Motor Heat (MBH) = 2.55 x BHP  
 Data Includes wet coil pressure drop

## Evaporator Fan Performance - TTV 400

English Units

		External Static Pressure (in. wg)																		
		0.5		0.6		0.8		1.0		1.2		1.4		1.6		1.8		2.0		
CFM	RPM	BHP	RPM	BHP	RPM	BHP	RPM	BHP	RPM	BHP	RPM	BHP	RPM	BHP	RPM	BHP	RPM	BHP	RPM	BHP
9680	609	2.9	737	3.2	799	3.6	861	4.0	918	4.4	971	4.8	1021	5.2	1068	5.6	1115	6.2		
10140	631	3.3	754	3.5	812	3.9	873	4.4	930	4.8	983	5.2	1032	5.8	1078	6.2	1124	6.6		
11260	687	4.3	798	4.6	854	4.9	906	5.4	960	5.9	1014	6.4	1062	6.9	1108	7.4	1152	7.9		
12120	730	5.2	835	5.4	887	5.9	937	6.3	986	6.8	1036	7.4	1085	8.0	1131	8.6	1175	8.9		
12390	744	5.5	847	5.8	897	6.2	947	6.7	994	7.2	1043	7.8	1093	8.3	1139	8.9	1182	9.4		
13520	802	6.8	900	7.1	943	7.6	990	8.2	1035	8.7	1078	9.3	1123	9.8	1169	10.5	1213	11.1		
14670	863	8.6	954	8.9	996	9.4	1035	9.9	1079	10.6	1154	11.3	1200	12.1	-	-	-	-		

- Notes:**
- Standard motor is 7.5 hp (5.5 kW), 1<sup>st</sup> option high static motor is 10 hp (7.5 kW), 2<sup>nd</sup> option high static motor is 15 hp (11 kW)
  - To determine the power of the motor to be installed, the following correction factors to the fan Shaft Absorbed hp.  
 Fan motor hp = Absorbed Fan Shaft hp x Correction Factor  
 Correction Factor = 1.2 for Absorbed Fan Shaft < 10 kW (13.4 hp)  
 Correction Factor = 1.15 for Absorbed Fan Shaft > 10 kW (13.4 hp)  
 Fan Motor Heat (MBH) = 2.55 x BHP  
 Data Includes wet coil pressure drop



# Indoor Unit Fan Performance Data

## Evaporator Fan Performance - TTV 500

English Units

		External Static Pressure (in. wg)															
		0.5		0.6		0.8		1.0		1.2		1.4		1.6		1.8	
CFM	RPM	BHP	RPM	BHP	RPM	BHP	RPM	BHP	RPM	BHP	RPM	BHP	RPM	BHP	RPM	BHP	
12060	479	2.6	509	2.9	570	3.5	638	4.5	698	5.5	745	6.3	787	6.9	826	7.6	
12780	489	2.9	516	3.2	574	3.7	634	4.6	702	5.8	754	6.8	796	7.6	834	8.2	
13940	511	3.5	536	3.8	587	4.4	638	5.0	695	6.0	758	7.4	808	8.5	849	9.4	
15130	532	4.2	556	4.5	602	5.1	651	5.8	697	6.5	751	7.6	810	9.1	859	10.4	
16260	553	5.0	577	5.3	622	6.0	664	6.6	710	7.4	753	8.1	802	9.3	858	10.9	
17420	577	5.9	601	6.2	642	6.9	682	7.6	722	8.4	766	9.2	805	10.0	850	11.1	
18310	597	6.6	619	7.0	658	7.7	698	8.5	734	9.2	775	10.0	815	10.9	854	11.8	

## Evaporator Fan Performance - TTV 500 (Cont'd)

(Cont'd)		External Static Pressure (in. wg)							
		2.0		2.2		2.4		2.5	
CFM	RPM	BHP	RPM	BHP	RPM	BHP	RPM	BHP	
12060	865	8.2	904	8.9	943	9.6	963	9.9	
12780	871	8.9	97	9.6	944	10.3	963	10.6	
13940	885	10.2	920	10.9	953	11.6	970	12.0	
15130	899	11.5	934	12.3	967	13.2	983	13.5	
16260	907	12.4	947	13.7	982	14.7	998	15.2	
17420	902	12.8	951	14.6	992	16.0	1010	16.6	
18310	897	13.1	945	14.7	991	16.6	-	-	

### Notes:

- Standard motor is 10 hp (7.5 kW), 1<sup>st</sup> option high static motor is 15 hp (11 kW), 2<sup>nd</sup> option high static motor is 20 hp (15 kW)
- To determine the power of the motor to be installed, the following correction factors to the fan Shaft Absorbed hp.  
 Fan motor hp = Absorbed Fan Shaft hp x Correction Factor  
 Correction Factor = 1.2 for Absorbed Fan Shaft < 10 kW (13.4 hp)  
 Correction Factor = 1.15 for Absorbed Fan Shaft > 10 kW (13.4 hp)  
 Fan Motor Heat (MBH) = 2.55 x BHP  
 Data Includes wet coil pressure drop

## Evaporator Fan Performance - TTV 600

English Units

		External Static Pressure (in. wg)															
		0.5		0.6		0.8		1.0		1.2		1.4		1.6		1.8	
CFM	RPM	BHP	RPM	BHP	RPM	BHP	RPM	BHP	RPM	BHP	RPM	BHP	RPM	BHP	RPM	BHP	
14460	569	5.0	592	5.3	635	5.9	682	6.6	728	7.4	777	8.5	832	9.9	882	11.4	
14900	579	5.3	602	5.7	643	6.3	689	7.0	733	7.8	777	8.6	831	10.1	885	11.8	
15960	605	6.3	625	6.6	667	7.3	705	8.0	749	8.9	789	9.6	831	10.6	881	12.1	
17030	631	7.4	651	7.7	691	8.5	727	9.2	765	10.0	8.6	10.9	843	11.7	882	12.7	
18090	658	8.6	677	9.0	714	9.8	751	10.6	785	11.3	821	12.2	860	13.2	895	14.0	
19160	686	9.9	705	10.4	739	11.2	775	12.1	808	12.9	840	13.7	876	14.7	912	15.7	
20220	713	11.4	732	11.9	765	12.8	799	13.7	832	14.6	862	15.4	893	16.3	927	17.4	
21280	740	13.1	759	13.6	792	14.5	823	15.4	856	16.4	886	17.3	-	-	-	-	
21900	756	14.1	775	14.6	808	15.6	838	16.5	-	-	-	-	-	-	-	-	

## Evaporator Fan Performance - TTV 600 (Cont'd)

		External Static Pressure (in. wg)							
		2.0		2.2		2.4		2.5	
CFM	RPM	BHP	RPM	BHP	RPM	BHP	RPM	BHP	
14460	923	12.6	959	13.6	992	14.5	1008	14.9	
14900	929	13.1	966	14.2	999	15.2	1015	15.7	
17030	932	13.9	977	15.5	1014	16.8	-	-	
18090	928	14.2	977	16.1	-	-	-	-	
19160	931	15.1	973	16.6	-	-	-	-	
20220	945	16.6	-	-	-	-	-	-	
21280	-	-	-	-	-	-	-	-	
21900	-	-	-	-	-	-	-	-	

### Notes:

- Standard motor is 10 hp (7.5 kW), high static motor is 20 hp (15 kW)
- To determine the power of the motor to be installed, the following correction factors have to be applied to the fan Shaft Absorbed hp.  
 Fan motor hp = Absorbed Fan Shaft hp x Correction Factor  
 Correction Factor = 1.2 for Absorbed Fan Shaft < 10 kW (13.4 hp)  
 Correction Factor = 1.15 for Absorbed Fan Shaft > 10 kW (13.4 hp)  
 Fan Motor Heat (MBH) = 2.55 x BHP  
 Data Includes pressure drop due to filters and wet coil.

# Dimensional Data Condensing Unit

## RAUP 250

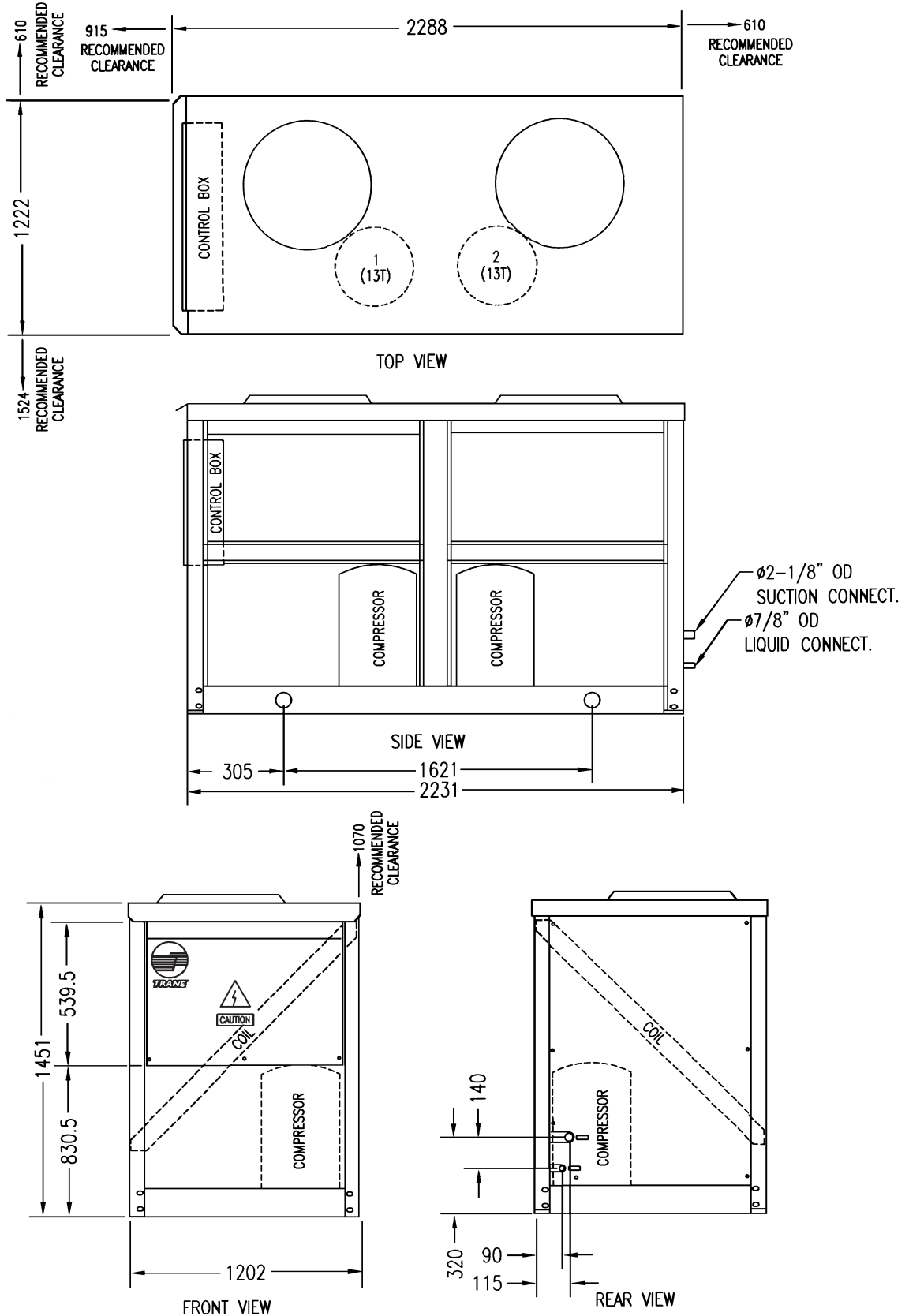

# Dimensional Data Condensing Unit

## RAUP 300

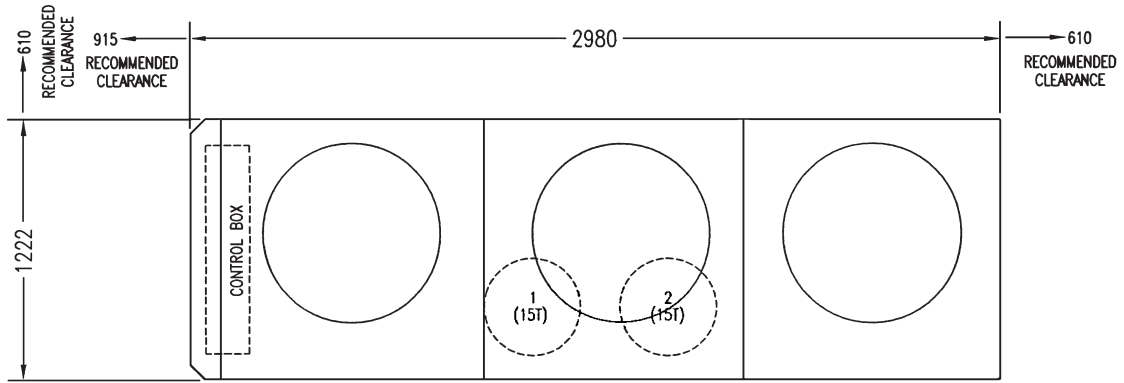

TOP VIEW

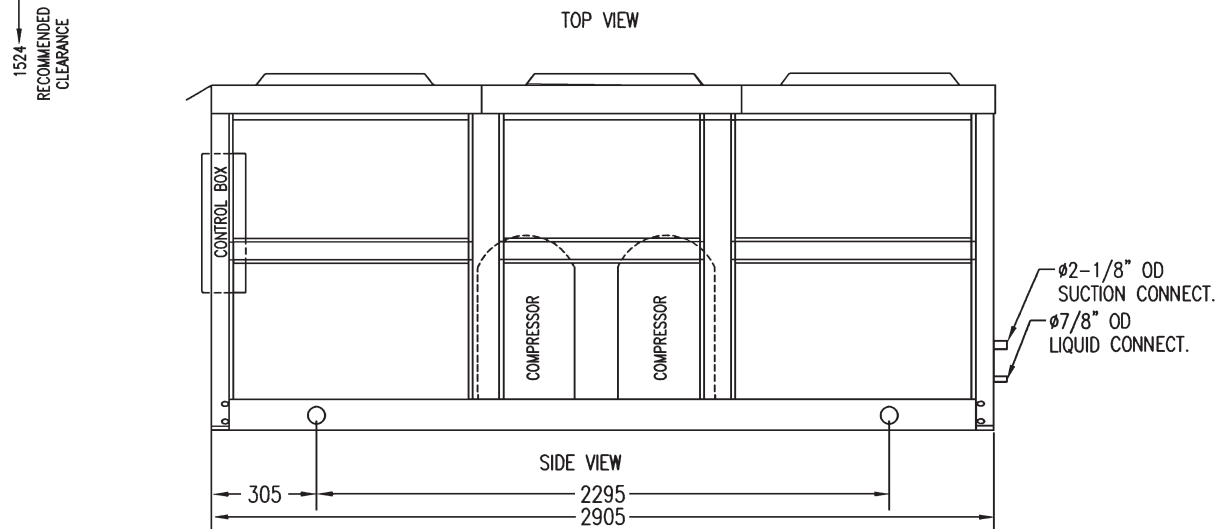

SIDE VIEW

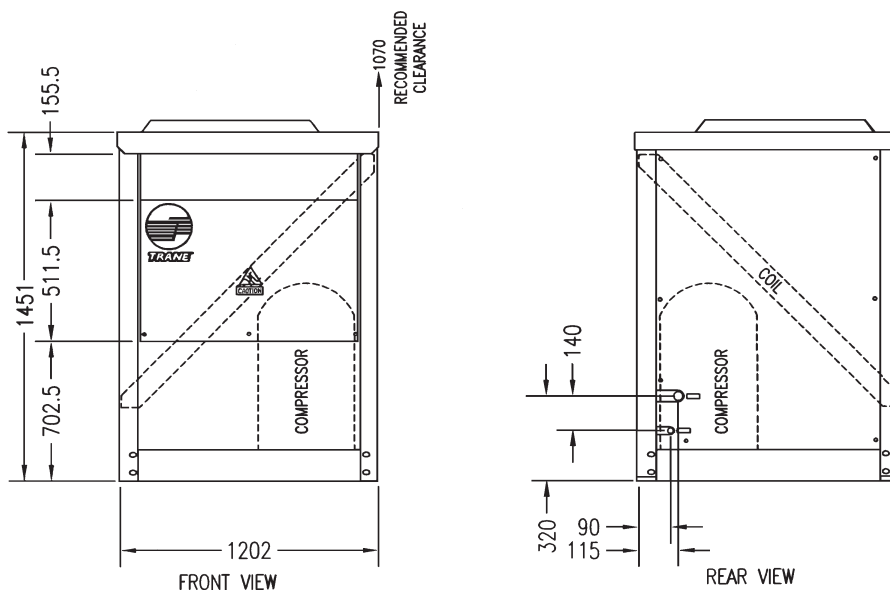

FRONT VIEW

REAR VIEW

# Dimensional Data Condensing Unit

## RAUP 400

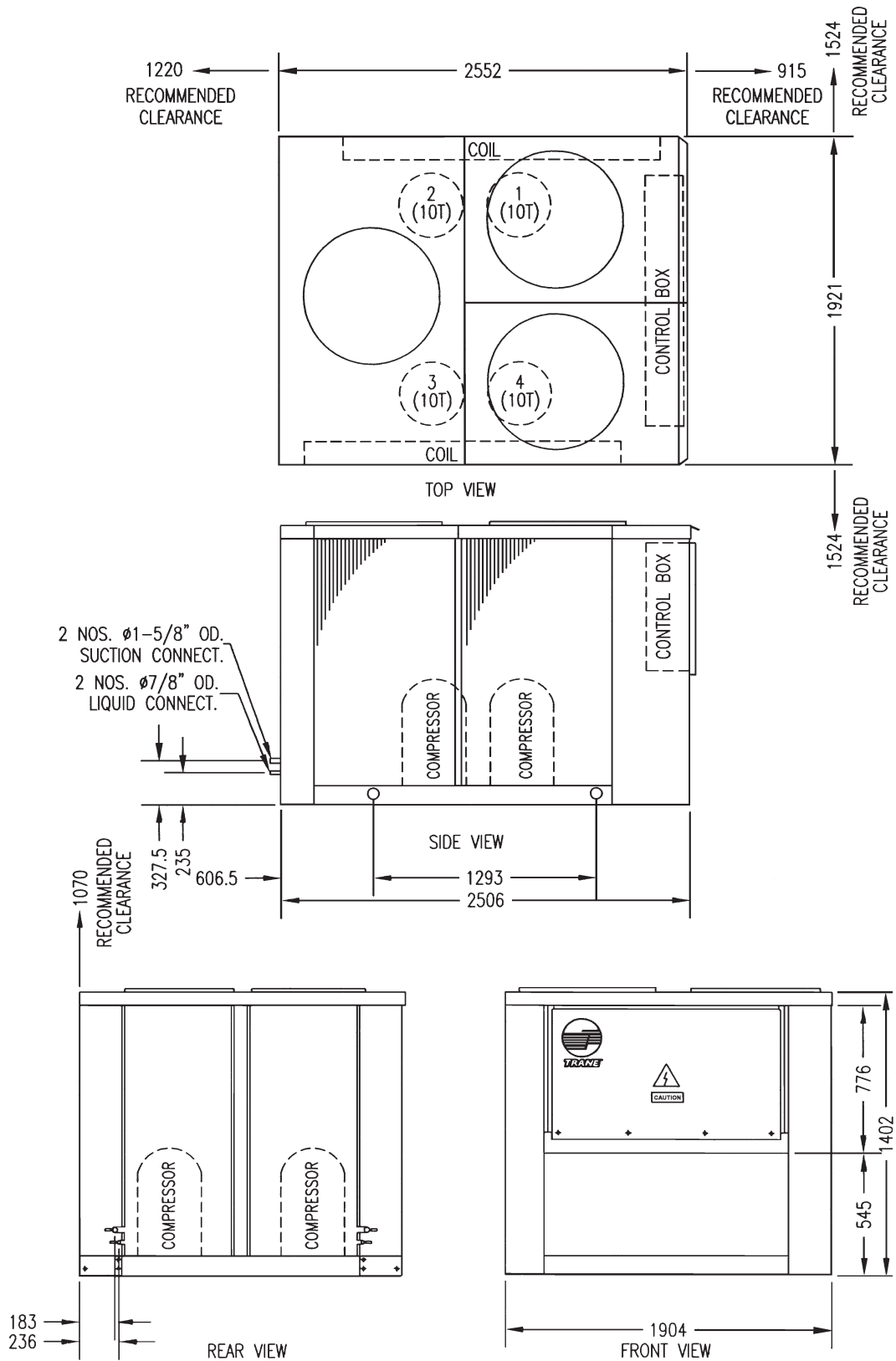

# Dimensional Data Condensing Unit

## RAUP 500

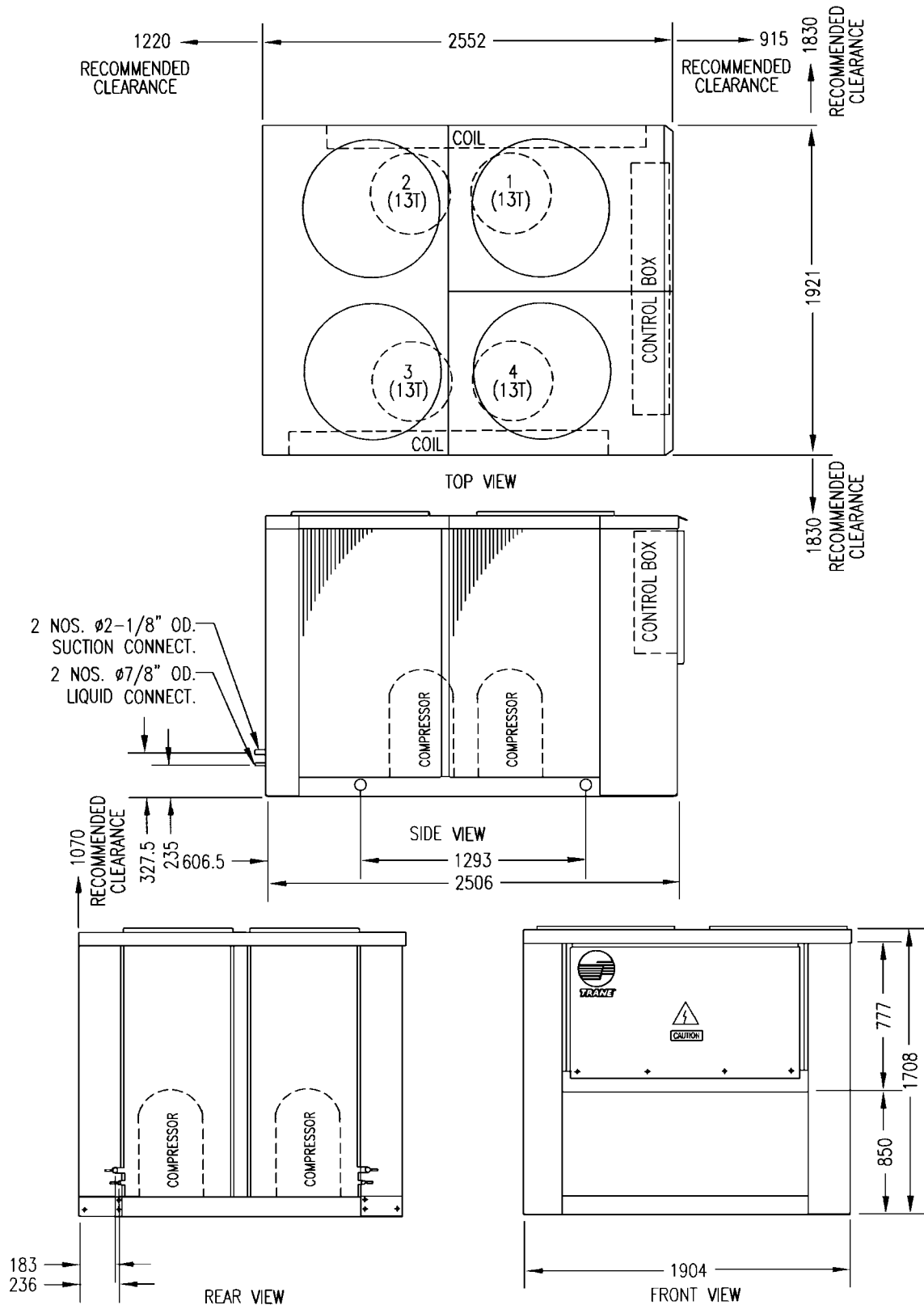





# Dimensional Data Condensing Unit

## RAUP 600

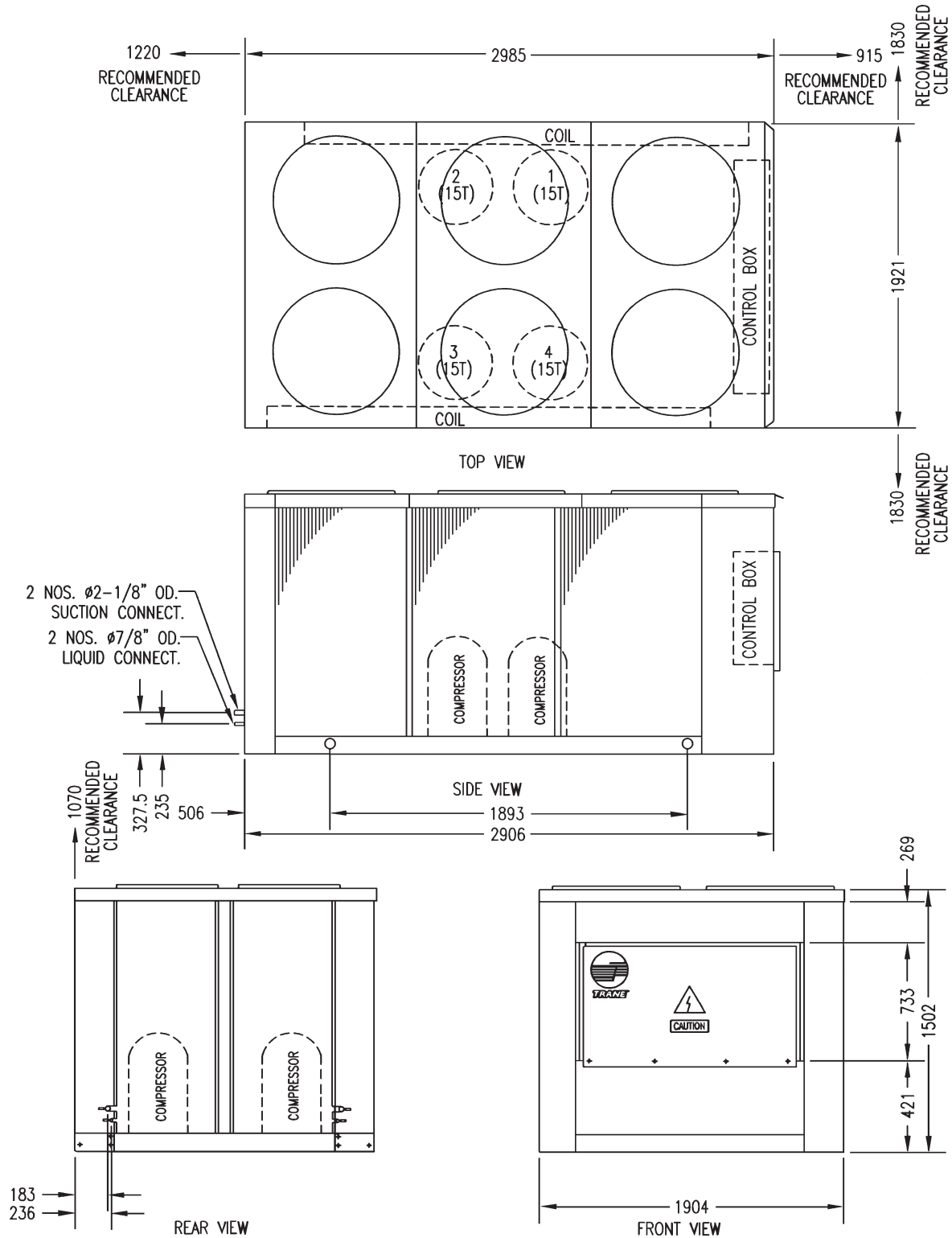

# Dimensional Data DX Air Handling unit

TTV 250

## FAN ARRANGEMENT 1

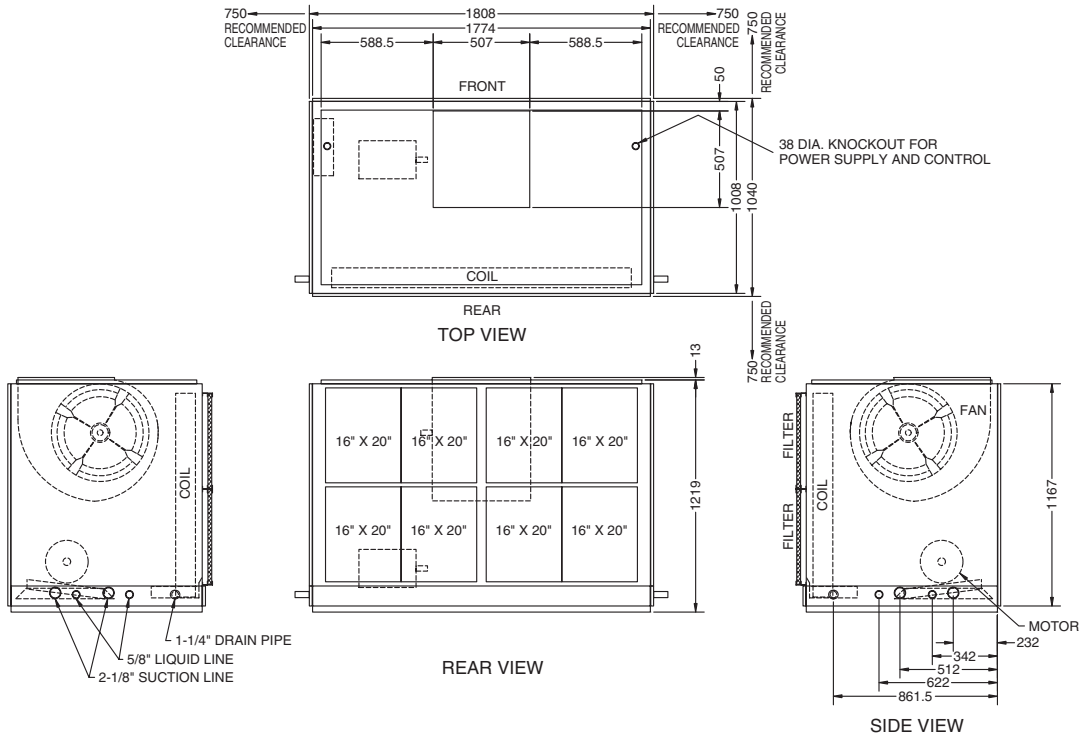

## FAN ARRANGEMENT 2

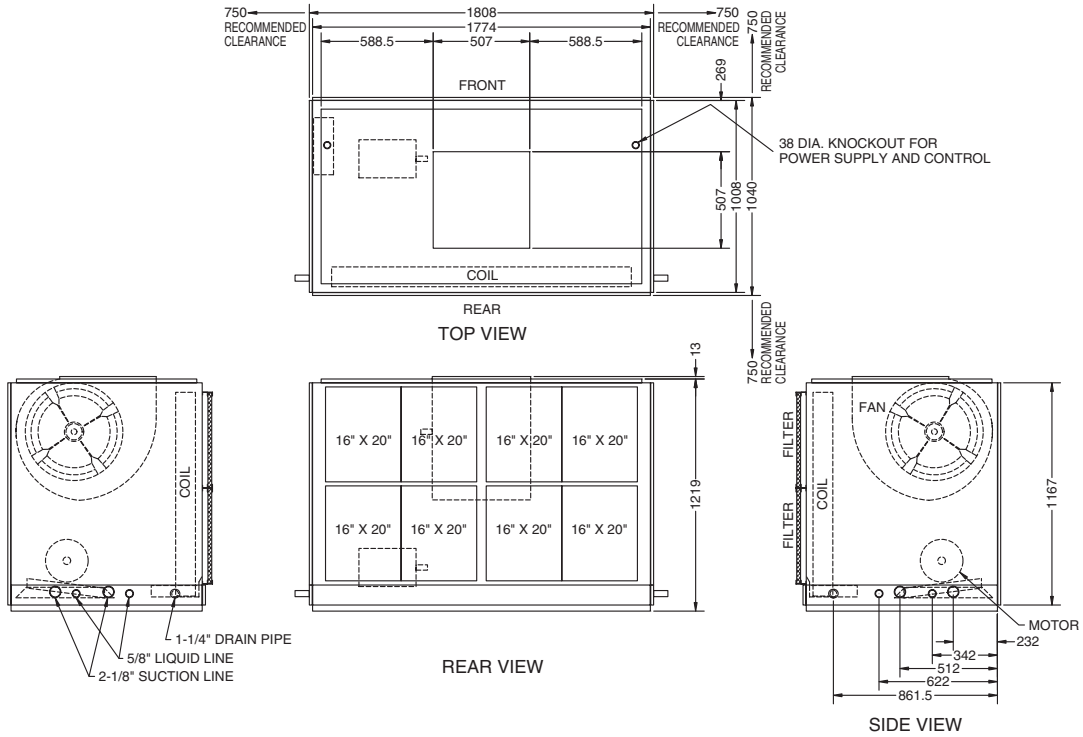

# Dimensional Data DX Air Handling unit

TTV 250

## FAN ARRANGEMENT 3

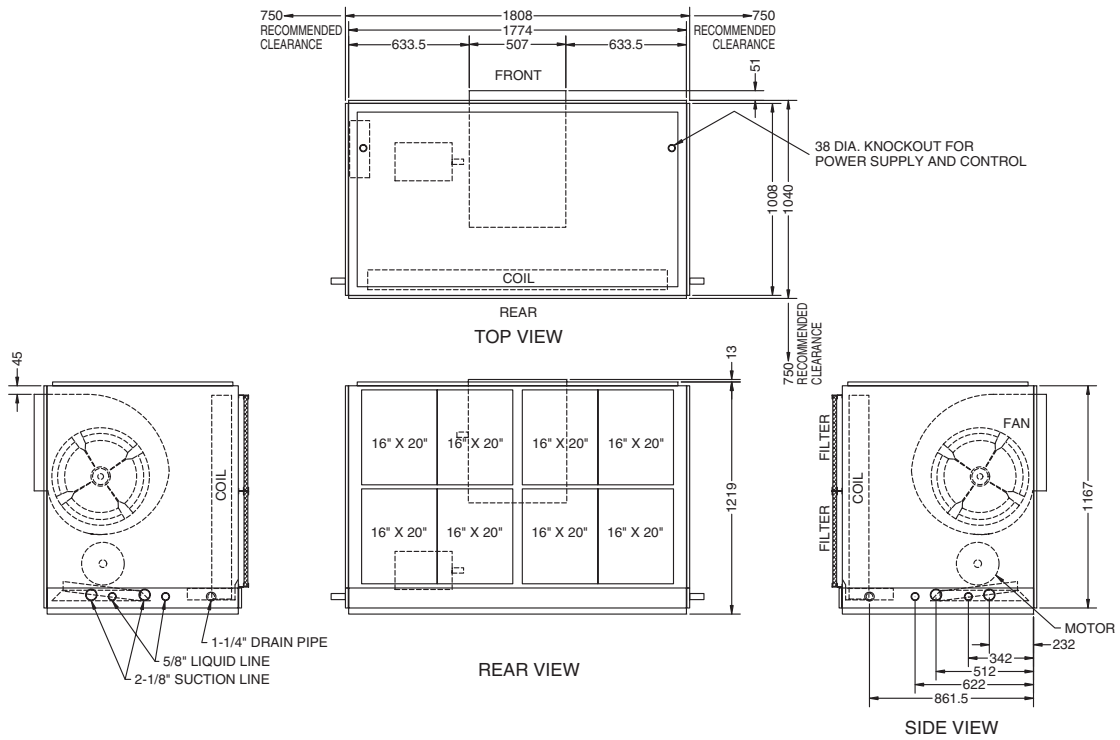

## FAN ARRANGEMENT 4

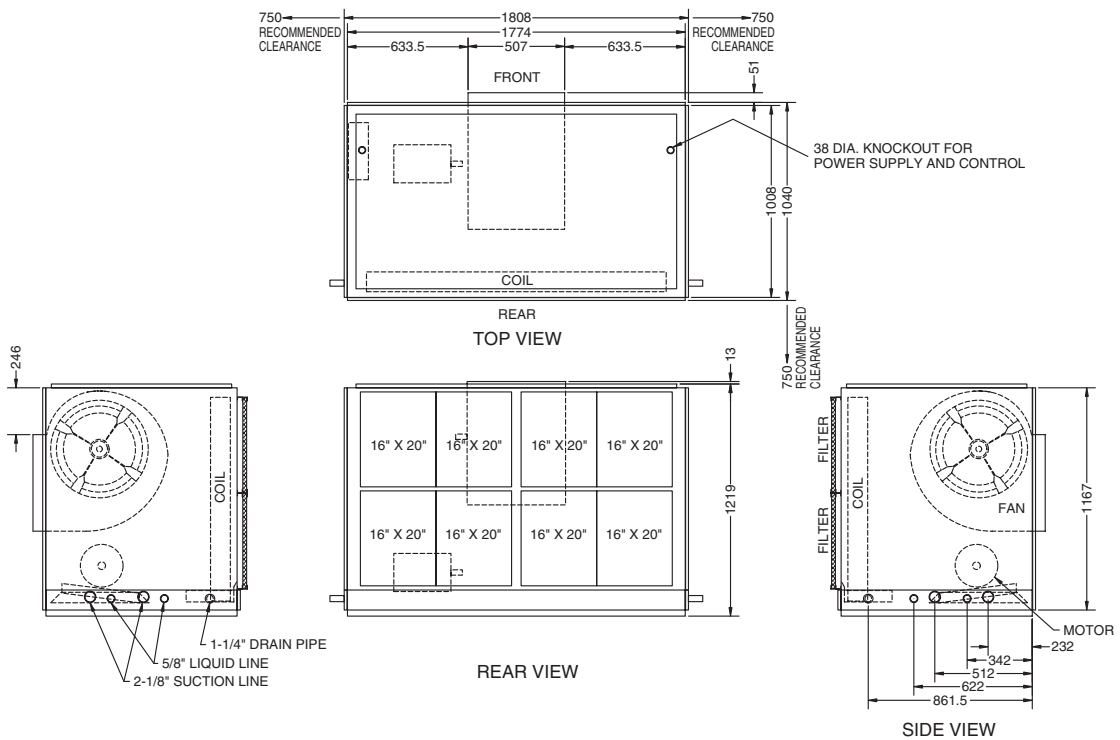

# Dimensional Data DX Air Handling unit

TTV 300

## FAN ARRANGEMENT 1

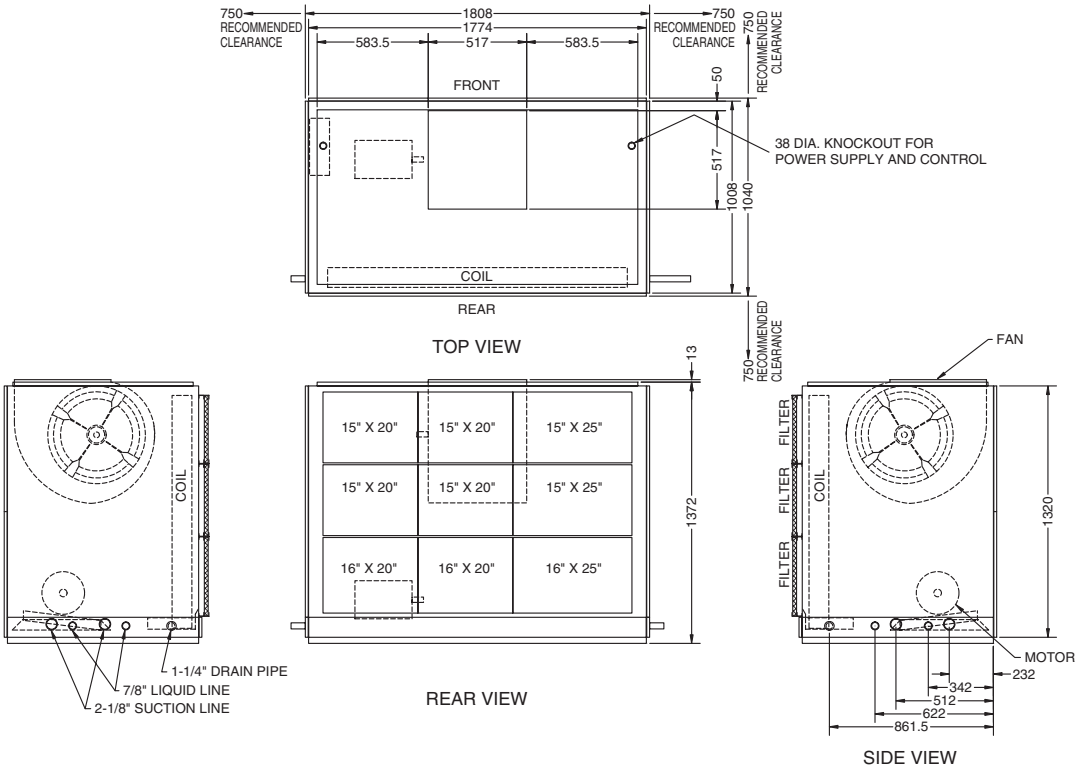

## FAN ARRANGEMENT 2

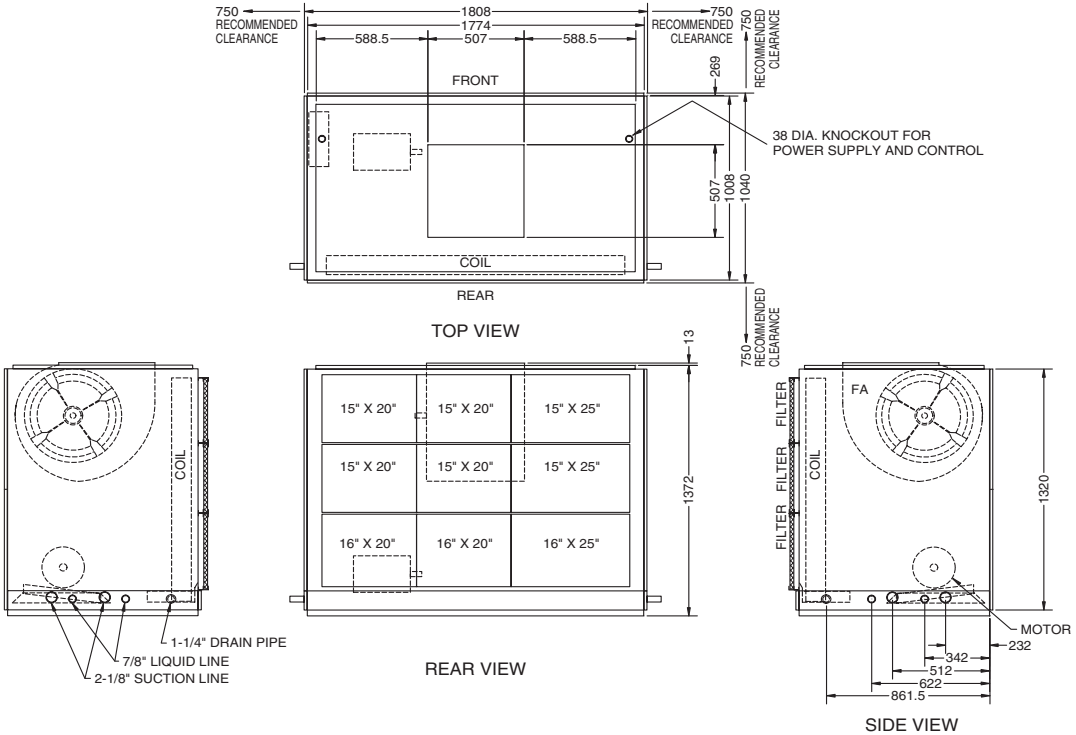

# Dimensional Data DX Air Handling unit

TTV 300

## FAN ARRANGEMENT 3

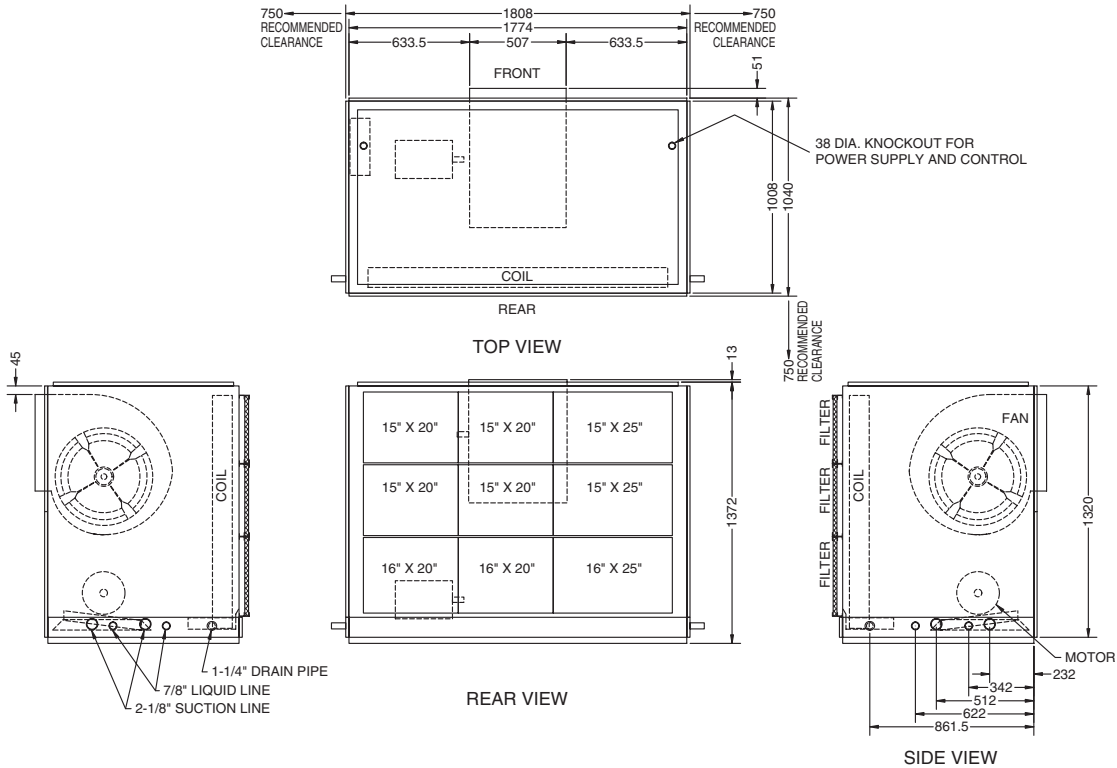

## FAN ARRANGEMENT 4

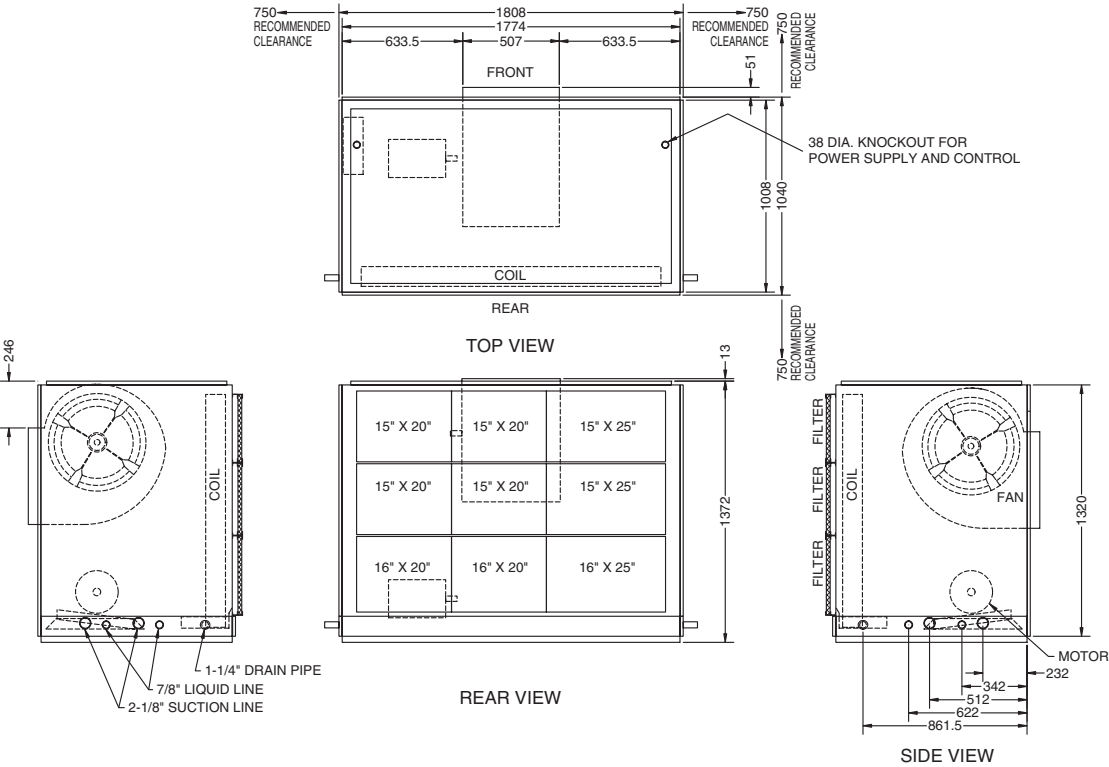

# Dimensional Data DX Air Handling unit

TTV 400

## FAN ARRANGEMENT 1

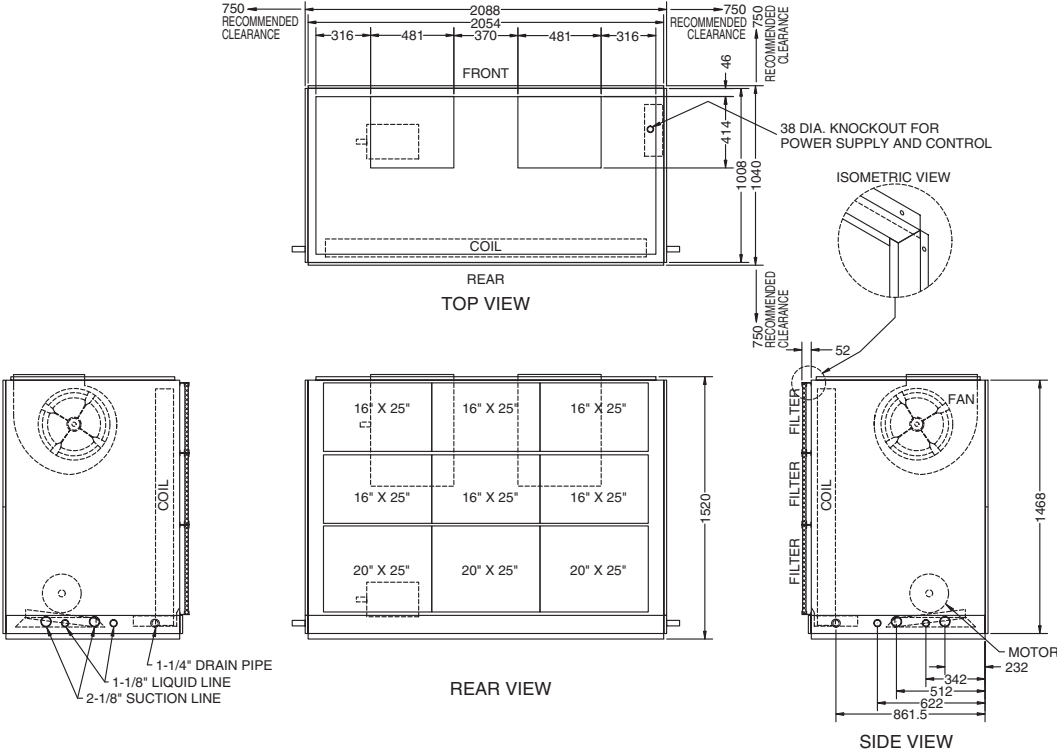

## FAN ARRANGEMENT 2

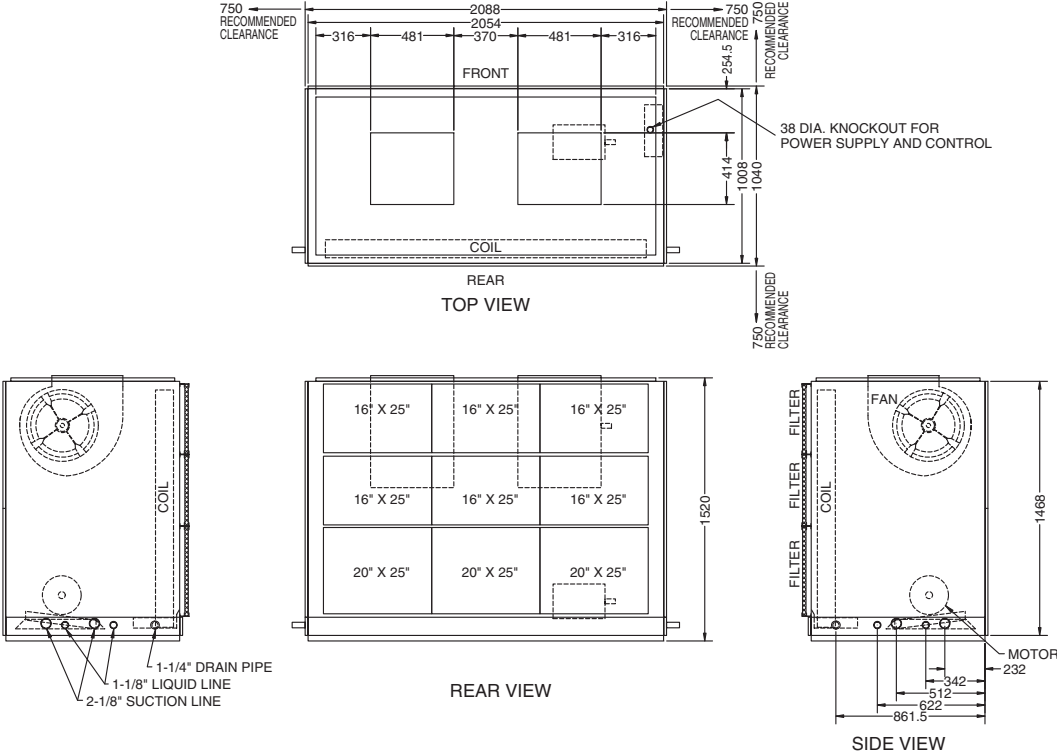

# Dimensional Data DX Air Handling unit

TTV 400

## FAN ARRANGEMENT 3

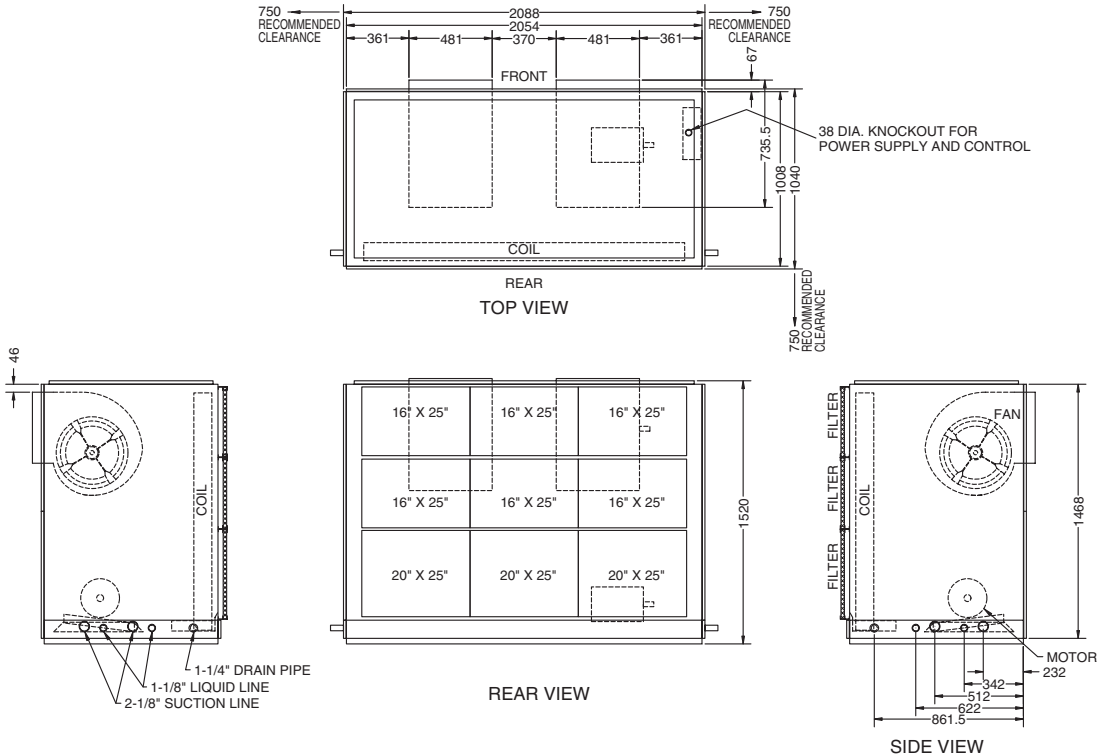

## FAN ARRANGEMENT 4

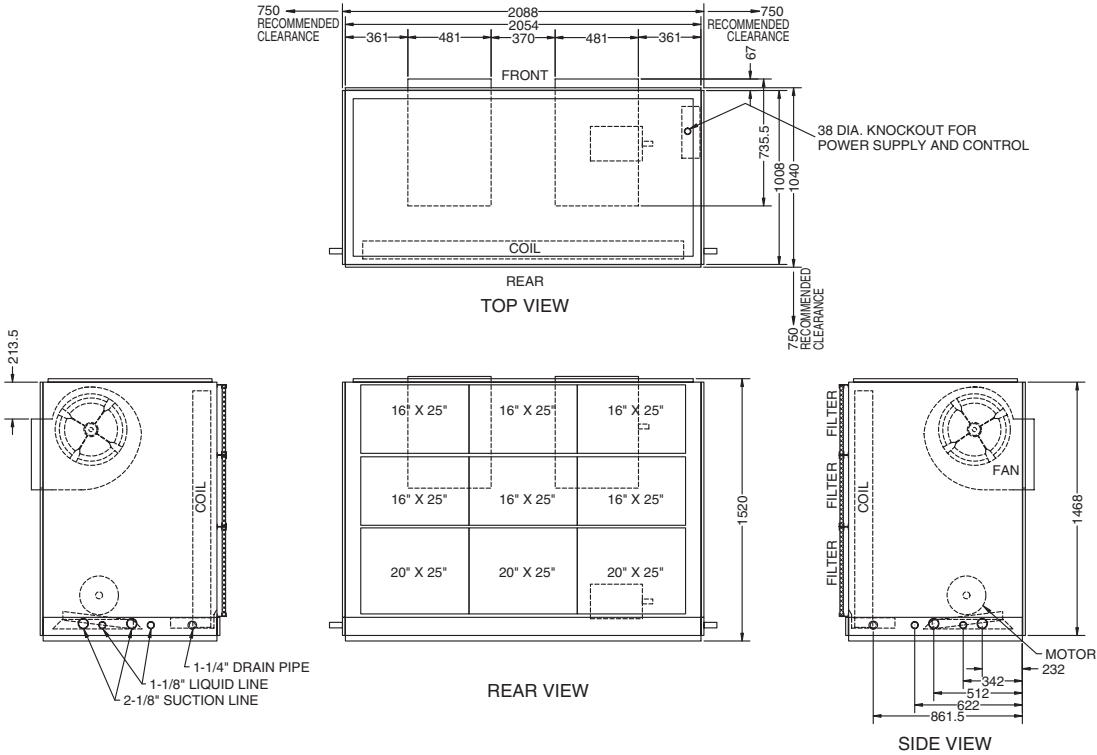

# Dimensional Data DX Air Handling unit

TTV 500

## FAN ARRANGEMENT 1

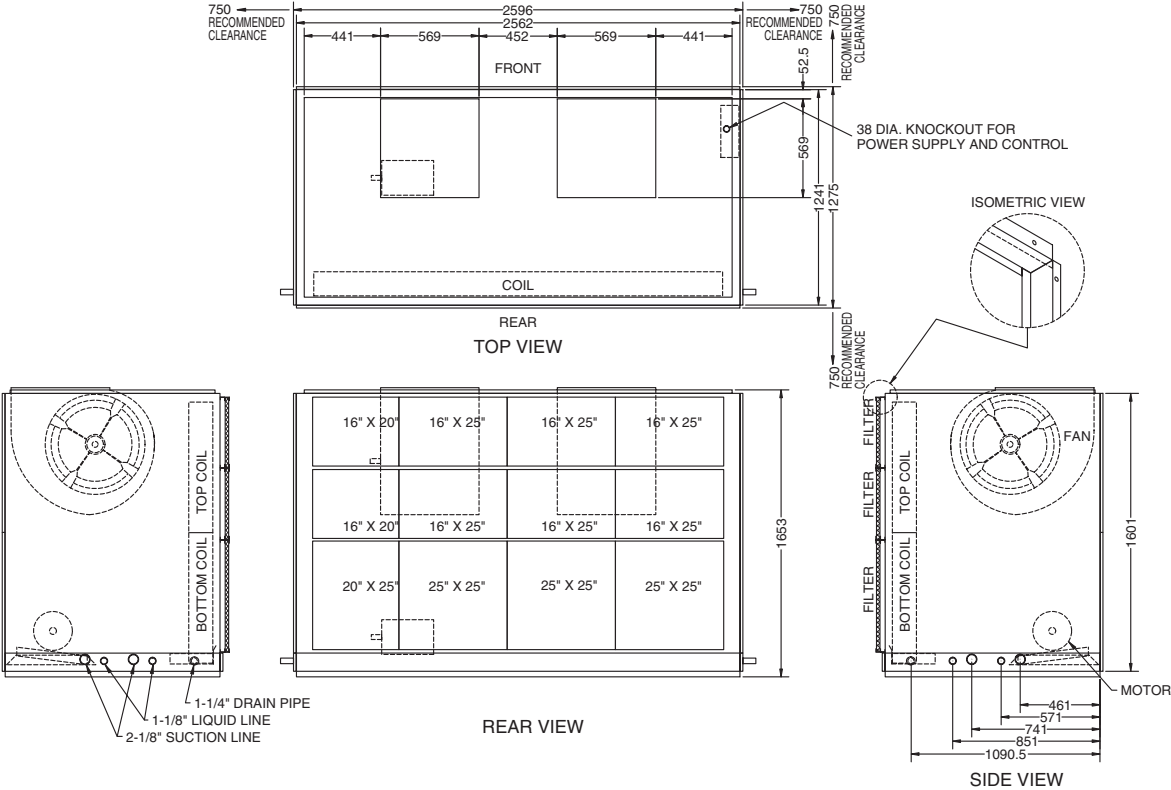

## FAN ARRANGEMENT 2

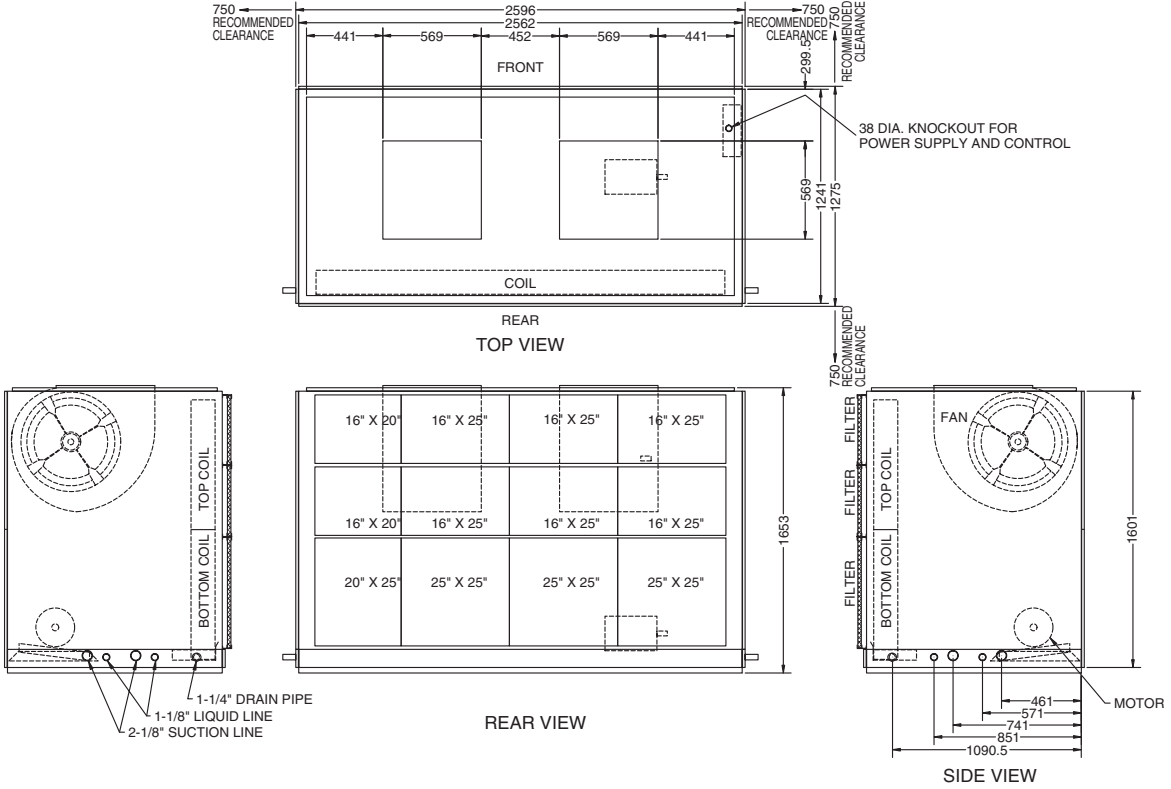



# Dimensional Data DX Air Handling unit

TTV 500

## FAN ARRANGEMENT 3

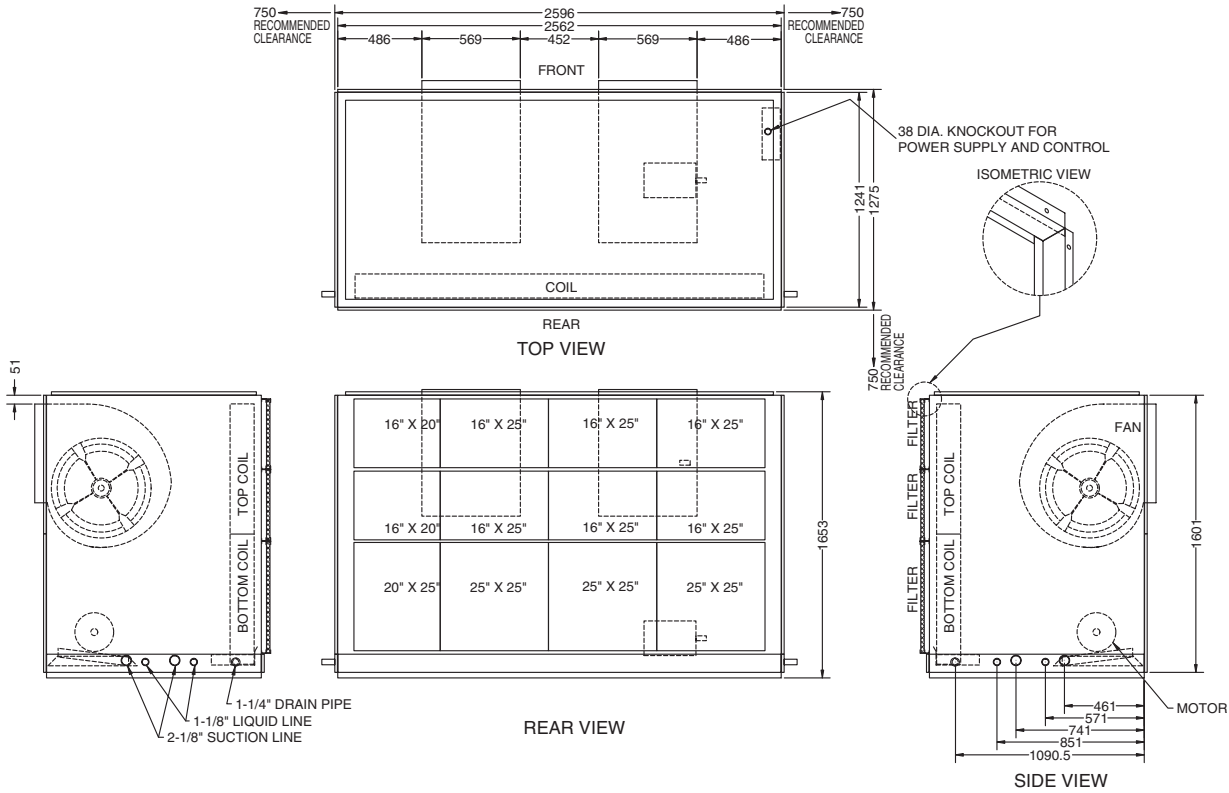

## FAN ARRANGEMENT 4

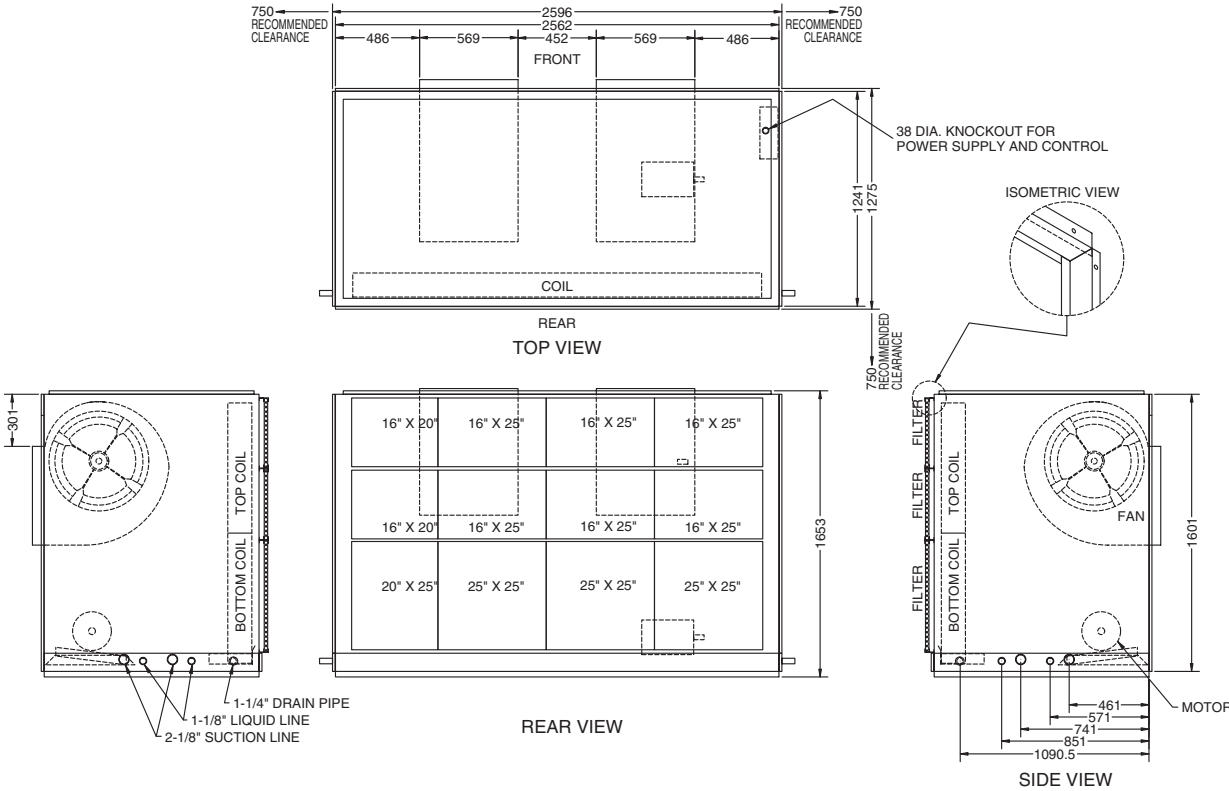

# Dimensional Data DX Air Handling unit

TTV 600

## FAN ARRANGEMENT 1

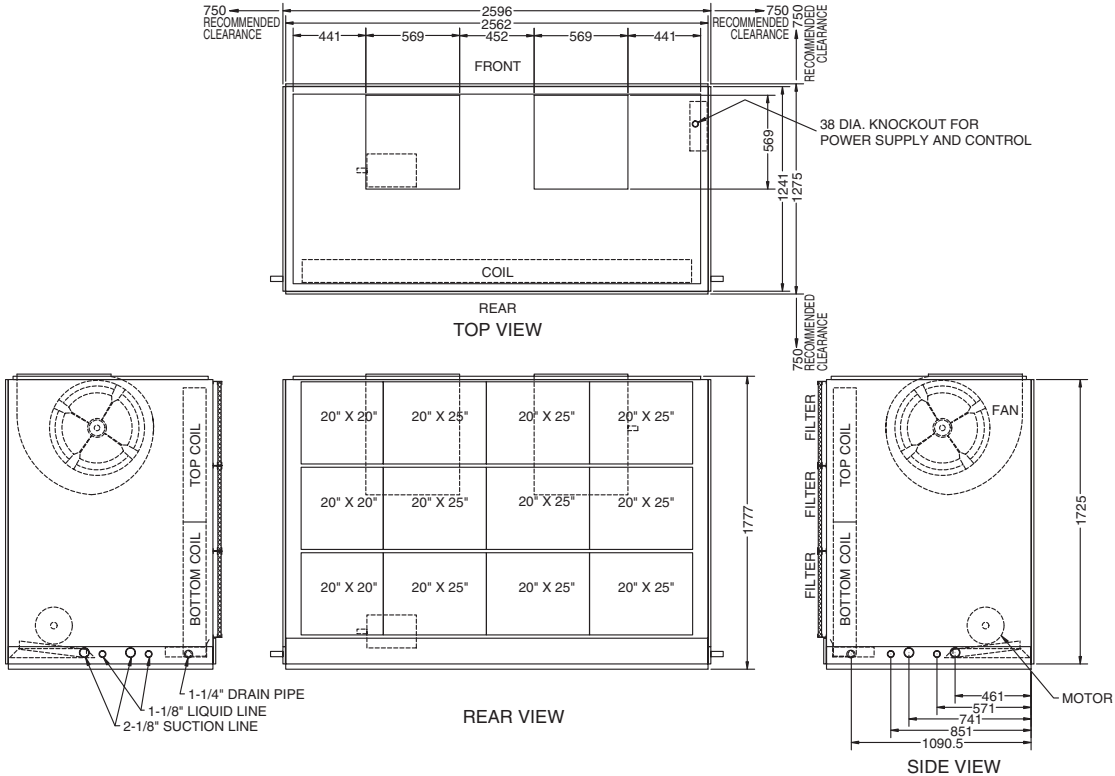

## FAN ARRANGEMENT 2

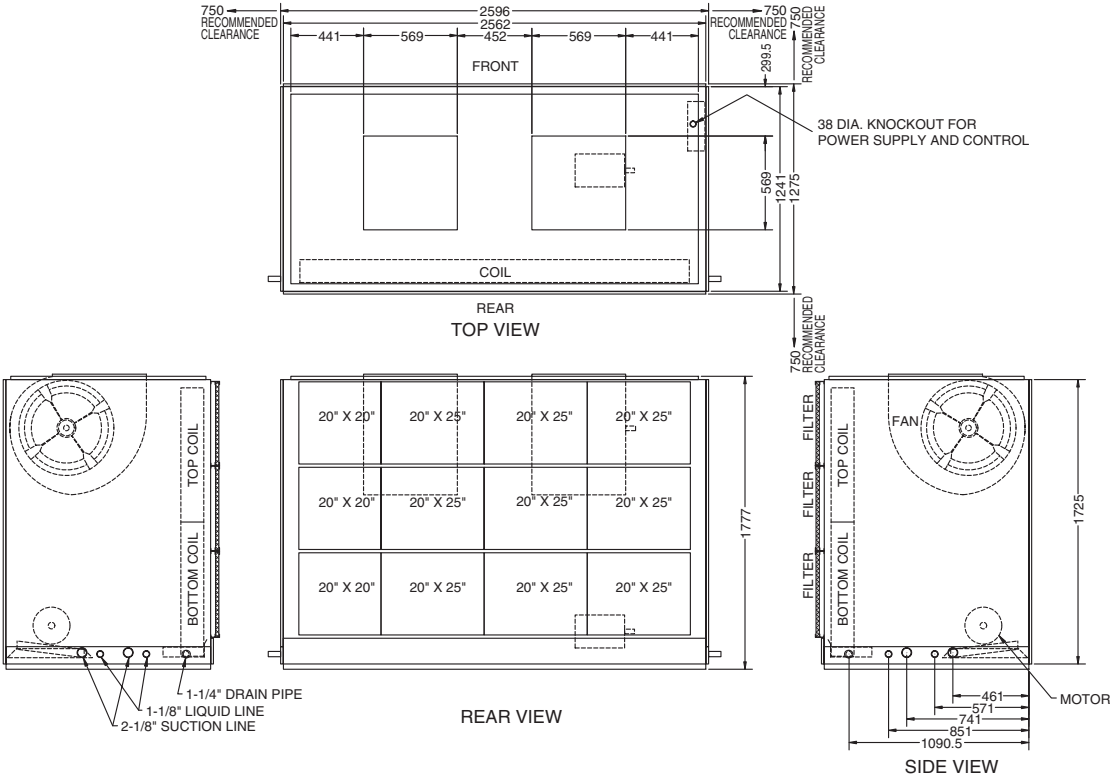

# Dimensional Data DX Air Handling unit

TTV 600

## FAN ARRANGEMENT 3

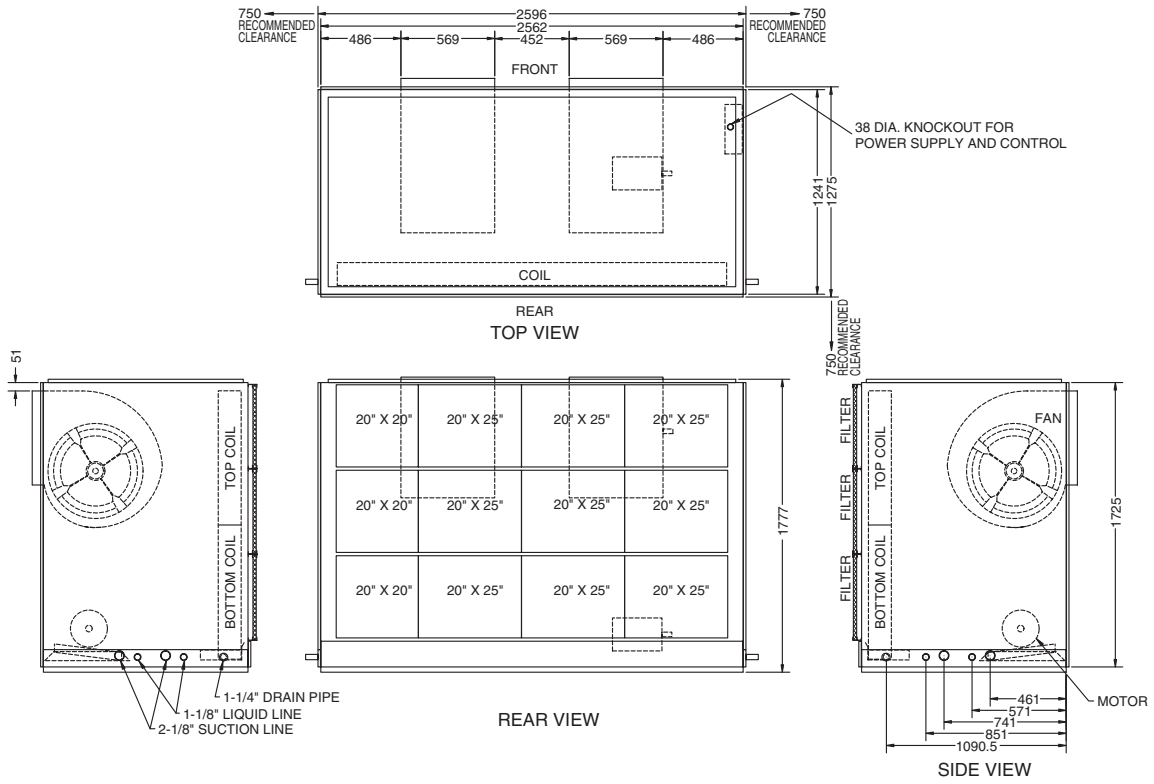

## FAN ARRANGEMENT 4

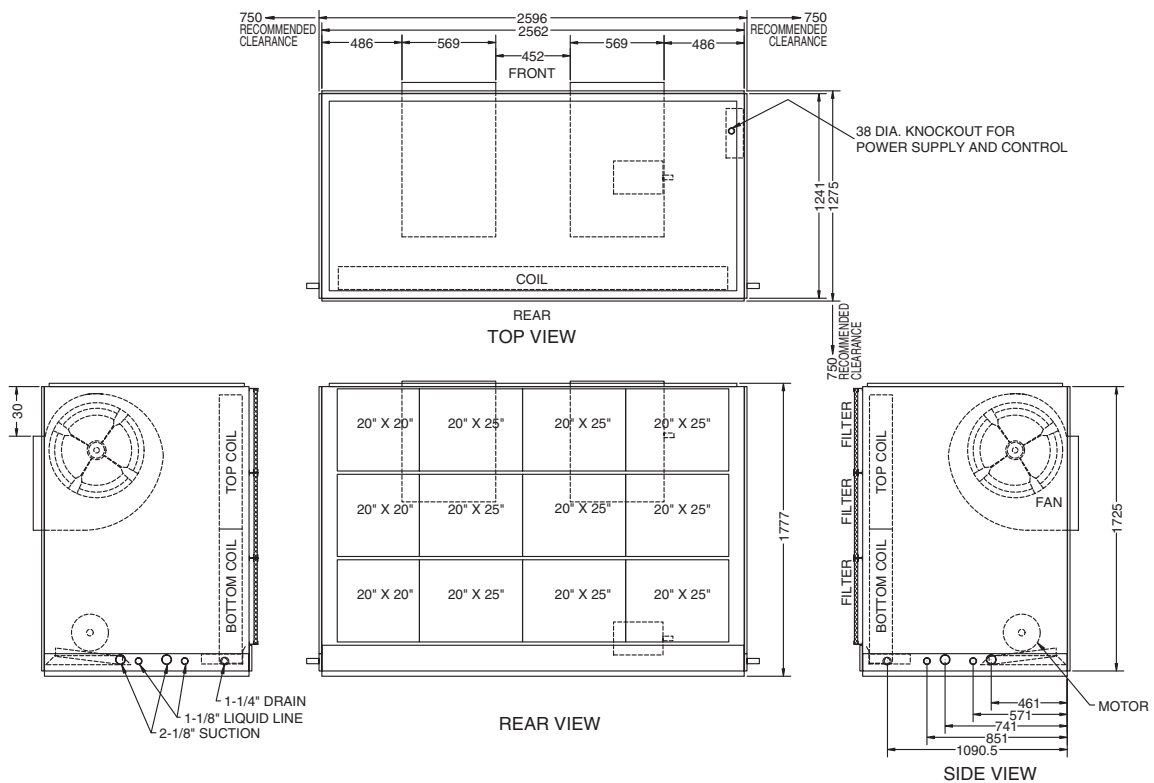



# Mechanical Specifications Outdoor Unit

---

## **CASING**

The unit shall be designed for outdoor installation with completely factory assembled panels. Unit panels shall be constructed of 0.9 mm galvanized steel held in place by Allen key arrangements for easy removal. Exterior panels shall be cleaned, chemically treated and finished with a weather resistant oven-baked polyester powder paint. The entire unit shall be mounted on a galvanized sheet steel base for ease of shipment and handling.

## **COMPRESSOR**

The unit shall have hermetic, welded shell Trane designed scroll compressors. Scroll compressors shall be heavy-duty suction gas cooled type complete with suction screen centrifugal oil pump with dirt separator, oil sight glass, protective device for low and high pressure and compressor motor winding thermostat. Two manifold compressors on unit sizes RAUP 150 to RAUP 300, four compressors on two independent manifolded circuits on unit sizes RAUP 400 to RAUP 600.

## **CONDENSING COIL**

One vertical air-cooled condenser coil for RAUP 150 to RAUP 300, two vertical coils for RAUP 400 to RAUP 600.

The coil shall be made of 3/8" seamless copper tubes mechanically bonded to aluminium plate fins. The coils shall be leak and proof tested to 300 and 450 psig respectively, and dehydrated and charged with nitrogen. Optional corrosion resistant condenser coils are available for corrosive environments.

## **CONTROLS**

Protective devices for low pressure, high pressure, motor winding temperature thermostat current overload for compressors and time delay protection shall be provided. DOL starter shall be provided as a standard. Shutoff valves shall be an option. Micro Control Processors shall be standard on a RAUP's. Micro Controllers shall have diagnostics.

## **FAN**

Direct drive propeller fans shall be provided. Fan motors shall be protected with current overload protection.

## **SHIPMENT**

All units shall be shipped on a wooden skid with the compressor oil operating charge and a R22 holding charge.

# Mechanical Specifications Indoor Unit

---

## **UNIT CASING**

The unit framework shall be 3 mm ga. GI steel. Exterior panels shall be fabricated from 1.2 mm ga. galvanized steel. All panels shall be cleaned and coated with a baked polyester powder paint. The base frame shall be welded 3mm galvanized steel.

All panels in contact with air stream shall be insulated with 1 inch 2 pound density fibre glass insulation covered with aluminium foils to prevent contact of moving air with insulation. All panels shall be removable to ensure proper access for servicing and maintenance. Removable panels shall be secured with bolts.

## **FOOTPRINT**

To save building space all models shall be placed against wall with return air from the front and general service from the sides.

## **COOLING COIL**

The evaporator coil shall be one-half inch or three-eighth inch OD seamless copper tubes mechanically expanded into aluminium fins.

Coils shall have at least two independent circuits for good part load capability.

Coils shall be proof tested at 375 psig and leak tested at 250 psig. Thermal expansion device shall be of direct expansion type with external equalizers, (Capillary tubes shall not be acceptable).

The drain pan shall be fabricated of galvanized steel, insulated to prevent any condensation, and mastic coated to prevent corrosion.

## **REFRIGERANT CIRCUIT**

Refrigerant circuits shall be independent or manifolded and shall include pressure access ports (high and low pressure) filter driers, and charging valves. The circuits shall be lead tested and factory charged with N2.

## **FANS**

Supply fans shall be of double width double inlet forward curved centrifugal fans statically and dynamically balanced. The drive components shall include fixed pitch drives and multiple V-belts. The drives shall be factory run tested and balanced. The supply fan motor shall be totally enclosed fan cooled.

## **STARTERS**

Unit mounted DOL fan motor starters are available as a standard feature.

## **HI-STATIC MOTOR (OPTIONAL)**

Optional factory mounted oversized fan motor for high external static pressure application.



**TRANE®**

Trane Thailand  
7th Floor, Ploenchit Center Building  
2 Sukhumvit Road, Klongtoey  
Bangkok 10110  
Amair Limited  
35 Mu 8, Poochaosamingprai Road  
Samrong Tai, Samutprakarn 10130  
<http://www.trane.com>  
An American Standard Company



---

Literature Order Number SSA5-PRC 003-EN

---

Supersedes Sep 2006

---

Stocking Location Soft Copy Only

---

**บริษัท แอมแอร์ จำกัด** 35 หมู่ 8 ถนนปู่เจ้าสมิงพราย ต.สำโรงใต้ อ.พระประแดง จ.สมุทรปราการ 10130

Since The Trane Company has a policy of continuous product and product data improvement, it reserves the right to change design and specifications without notice.